

RB650 & RB750

Ride-on-Scrubber Drier
Battery

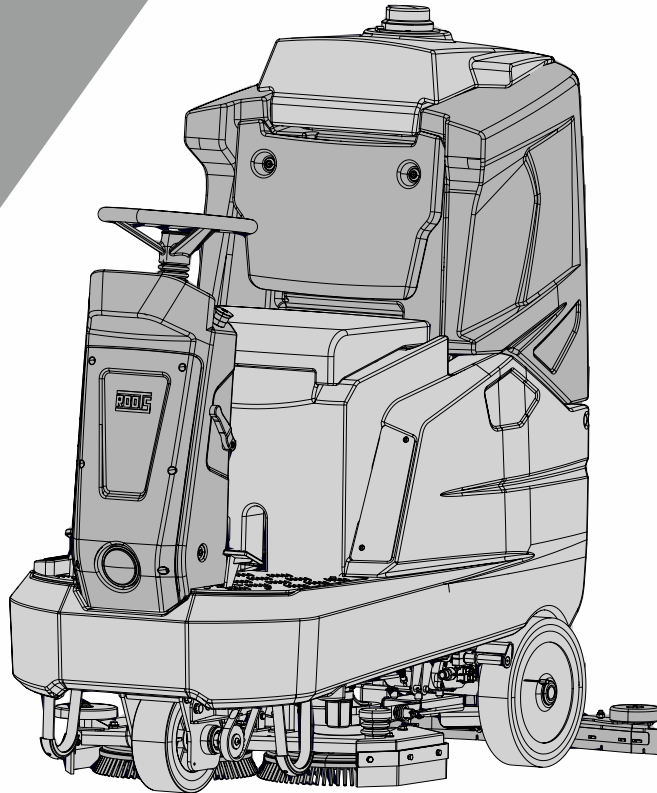

i 24V/200Ah



Read this manual completely and understand the instructions before operating the machine.
"English Version"

Operator's Manual

TABLE OF CONTENTS



	Table Of Contents & Important Note	3
	Introduction	5
	Technical Specifications	7
	Support	12
	Safety Instructions	14
	Know Your Machine	21
	Working Principle	26
	Controls	28
	Machine Operation	41
	Maintenance	64
	Troubleshooting	85
	Do & Don'ts	88
	Operator Notes	89

IMPORTANT NOTE:

Roots Multiclean Ltd. (RMCL) is not liable for any legal claims that may arise as a direct or indirect result of the contents of this manual.

Roots Multiclean Ltd.
R.K.G. Industrial Estate, Ganapathy,
Coimbatore - 641 006, India.

MACHINE DATA

Please fill at the time of installation for future reference:

Model No. - _____

Serial No. - _____

Installation Date - _____

P/N: 557540003-00, Rev-A, 11/2018

Prepared by KM, NPM TD Dept.



INTRODUCTION

INTRODUCTION



PREFACE

Dear Customer,

We are pleased with you having chosen the **RB650/RB750 Ride-on-Scrubber Drier** for your cleaning requirements. Backed by our industry expertise that spans across two decades, we assure you that the machine comes with ROOTS promise of quality, efficiency and performance.

We advise you to carefully read through the instructions prior to the operation of the machine. This manual contains detailed instructions for the proper operation of the machine, along with important information regarding its handling, care, maintenance and service needs.

We are sure that you will find the machine and its performance to your utmost satisfaction. Once again, we thank you for choosing us as a trusted partner for your cleaning requirements.

Usage, Handling & Modification

Use of the product beyond the specified scope of functioning is deemed improper and the manufacturer cannot be held liable for any damage which may arise due to this.

This machine may be used only by persons who are trained or are familiar with the machine and are aware of the possible hazards involved. The appropriate Accident Prevention Regulations as well as applicable general regulations pertaining to Safety and Health at the work place must be adhered to by the user.

Modifications made to machine without the manufacturer's consent will relieve the manufacturer of responsibility and any possible liability for consequential damage.

Notes on Warranty

Refer the Warranty manual supplied along with the machine.

Acceptance of the Machine

On arrival of the machine at the shipping address, please check for any damage that may have occurred as a result of transit. In the event of any such damage, the purchaser is bound by responsibility to send a claim letter to the concerned authorized dealer with a copy of the invoice. The letter should be sent within 24 hours of receipt of the machine.

NOTE:

ILLUSTRATIONS SHOWN IN THIS MANUAL ARE FOR REPRESENTATIVE PURPOSE ONLY. ACTUAL PRODUCT MAY VARY.

ROOTS reserves the right to change the product or contents of this manual without prior information.

For instructions regarding usage, maintenance and service of Engine, Battery, Motors, Blowers or other OEM components kindly refer to their manufacturers manual supplied along with the machine.



Prior to first operation, read the manual carefully and strictly comply with the instructions contained.

The Operator's Manual is an integral part of the machine and must not be misplaced.



TECHNICAL SPECIFICATION - RB650 STANDARD/PREMIUM

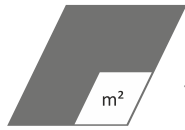
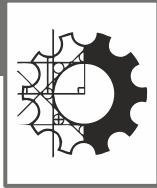

Theoretical area coverage
- 4225 m²/hr



Vacuum pressure - 1000 mm of H₂O



Gradient (Max) - 11 %



Working speed - 6.5 km/hr
Travel speed - 7 km/hr
Minimum running time - 4 hrs

Turning circle in aisles -
1250 mm

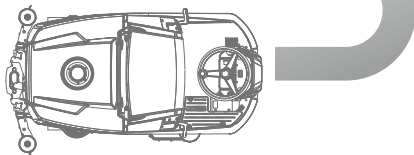

Weight of the machine with batteries & water - 450 kg (Std/Premium), 455 kg (Std SS/Premium SS)

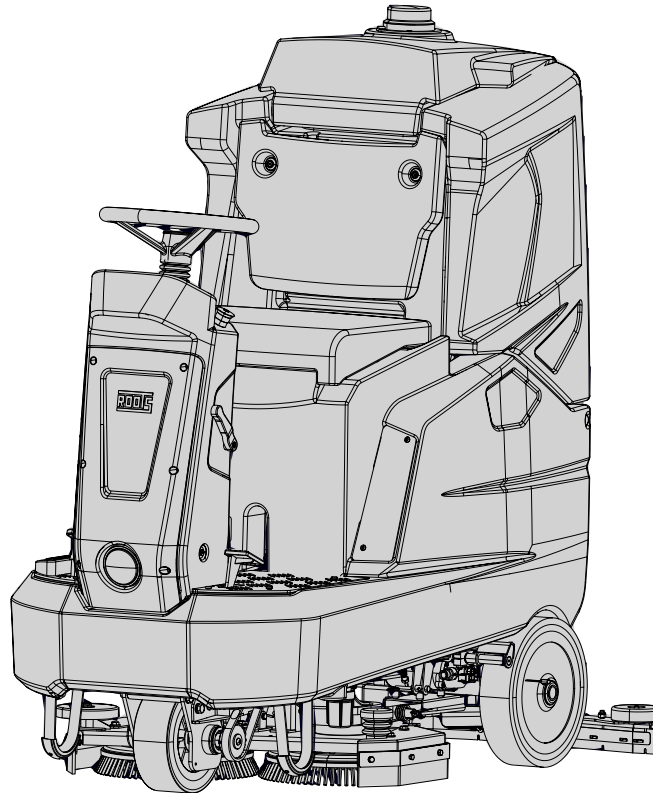

Fresh water tank - 100 L
Dirty water tank - 100 L

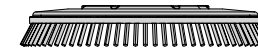

No. of brushes per machine - 2
Brush diameter - 333 mm
Brush speed (Min.) - 180 rpm
Scrubbing width - 650 mm
Brush load - 25 Kg



Power supply - 24 V DC
Battery rating - 200 Ah
Brush motor nominal power - 2 X 350 W
Vacuum motor nominal power - 400 W
Drive motor nominal power - 500 W



Water flow rate (max) - 3.3 lpm

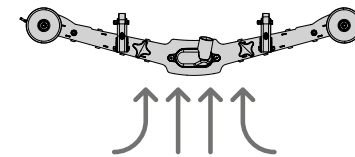

Suction width - 870 mm

TECHNICAL SPECIFICATION - RB750 STANDARD/PREMIUM

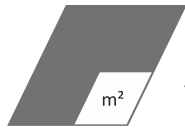
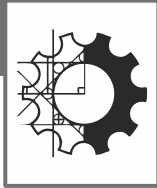

Theoretical area coverage
- 4875 m²/hr



Vacuum pressure - 1500 mm of H₂O



Gradient (Max) - 11 %



Working speed - 6.5 km/hr
Travel speed - 7 km/hr
Minimum running time - 4 hrs

Turning circle in aisles -
1250 mm

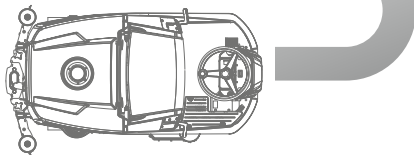

Weight of the machine with batteries & water - 470 kg (Std/Premium), 475 kg (Std SS/Premium SS)

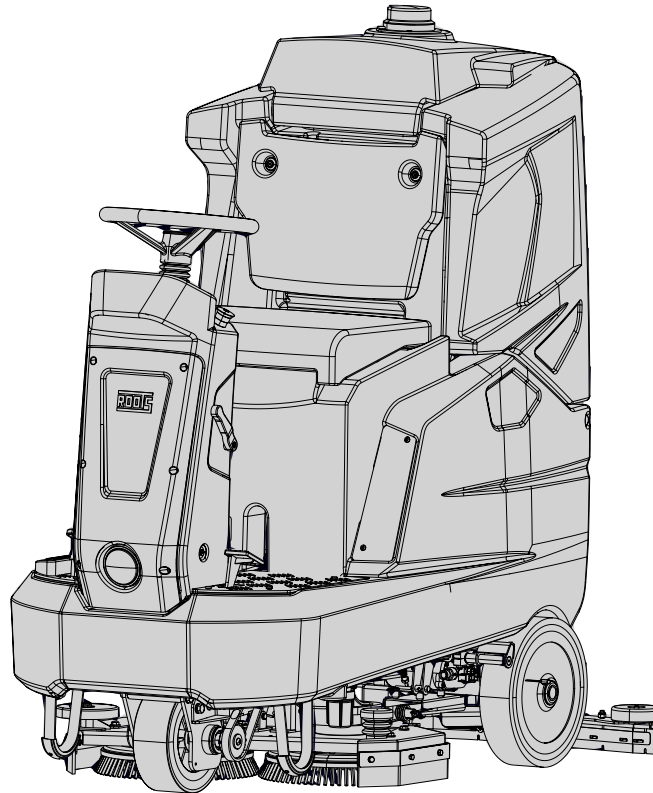

Fresh water tank - 100 L
Dirty water tank - 100 L

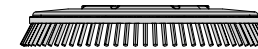

No. of brushes per machine - 2
Brush diameter - 385 mm
Brush speed (Min.) - 180 rpm
Scrubbing width - 750 mm
Brush load - 30 Kg



Power supply - 24 V DC
Battery rating - 200 Ah
Brush motor nominal power - 2 X 350 W
Vacuum motor nominal power - 550 W
Drive motor nominal power - 500 W



Water flow rate (max) - 3.3 lpm

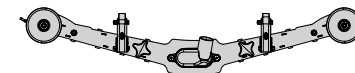

Suction width - 970 mm

TECHNICAL SPECIFICATION - RB650

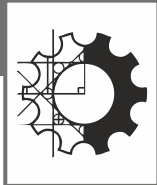

Dimensions for RB650:

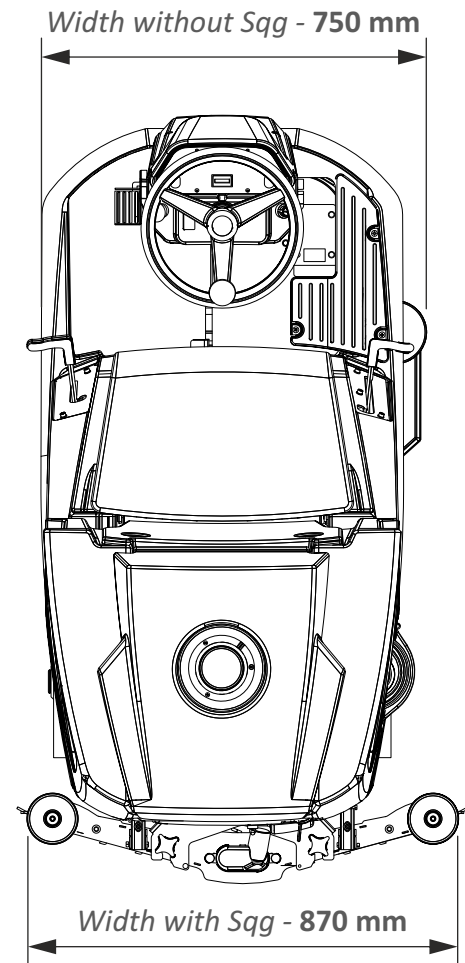
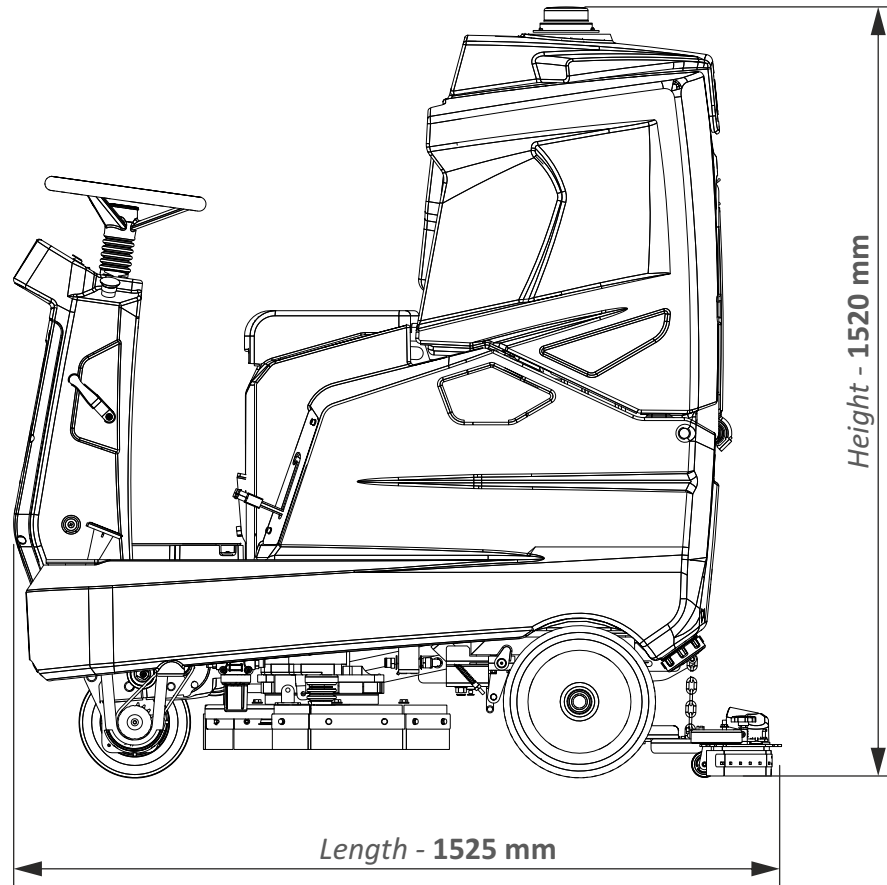

TECHNICAL SPECIFICATION - RB750

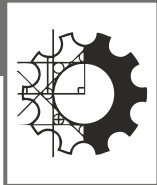

Dimensions for RB750:

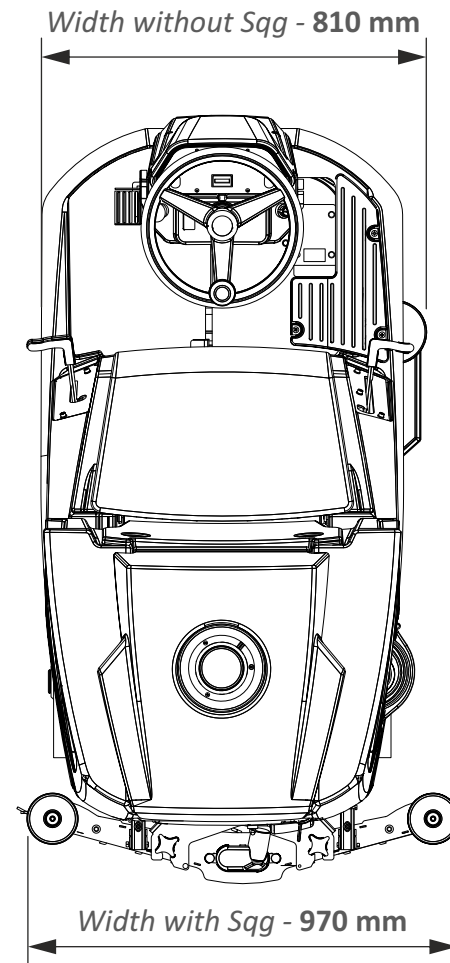
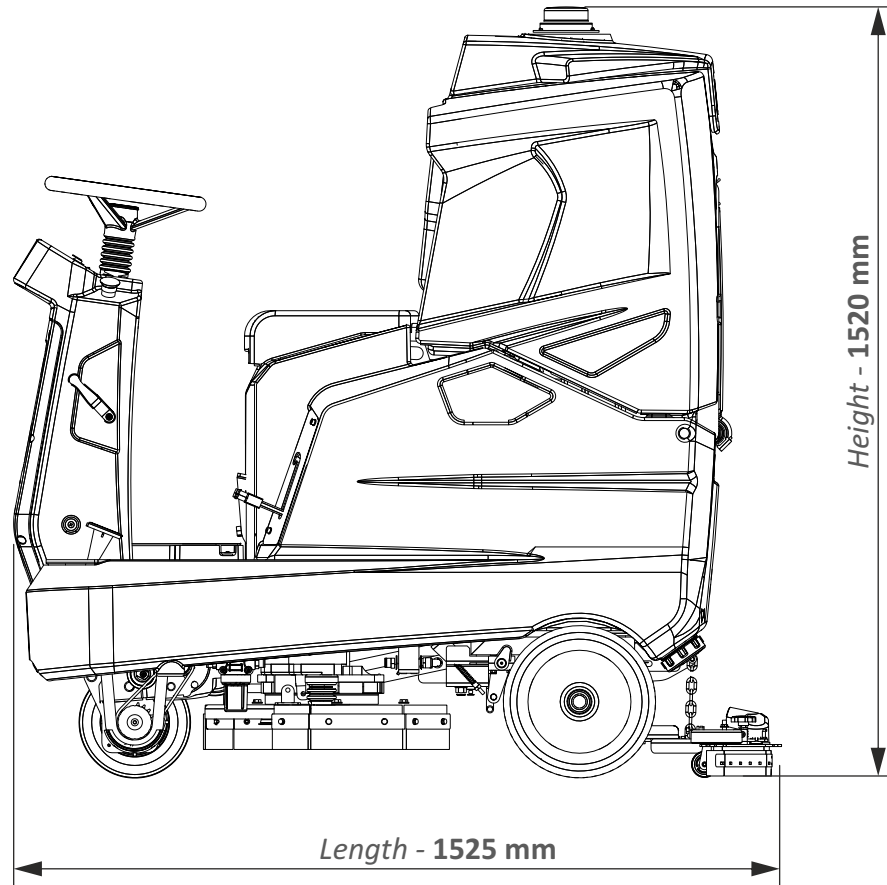



SUPPORT

AFTER SALES SUPPORT



AMC

CUSTOMER SUPPORT SYSTEM (CSS)

RMCL has a dedicated CSS Team to ensure prompt after sales service support with one call solution for all your complaints/concerns. Register your complaint or concern through the below toll free number for hassle free support. The customer support executive registers your complaint/concern and will keep you updated on the progress.

Toll Free Number:

1800 41 99 77 9

Our timings (Monday to Saturday):

8:00 am to 7:00 pm

Customer Support System Process

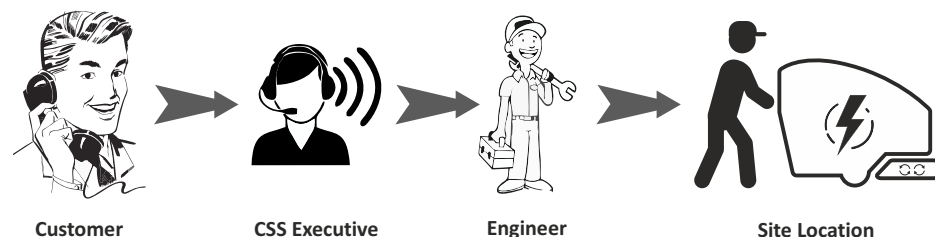

Our Address:

Roots Multiclean Ltd.

R.K.G. Industrial Estate, Ganapathy, Coimbatore - 641 006, India.

Phone: +91 (422) 4330 330, E-mail: rmclsales@rootsemail.com

Web: rootsmulticlean.com

Toll Free: **1800 41 99 77 9**

ANNUAL MAINTENANCE CONTRACT (AMC)

AMC or Annual Maintenance Contract is a professional and timely maintenance cover offered by RMCL to its customers. AMC takes care of scheduled and preventive maintenance services. Equipment under AMC qualifies for four scheduled visits and to a maximum of twelve unscheduled visits during the contract.

Advantages of AMC:

- Pan India network presence.**
- Maximum equipment uptime.**
- Focus on your business while we take care of your equipment.**
- Well trained engineers to take care of the equipment.**
- System driven scheduled periodic maintenance.**
- Genuine spare parts.**
- Toll free number assistance for breakdown.**



SAFETY INSTRUCTIONS

SAFETY INSTRUCTIONS



GENERAL SAFETY SYMBOLS



**Read
manual**

Prior to first operation, read the manual carefully and strictly comply with the instructions contained.



**Caution
(the machine)**

Important information on handling the machine in order to maintain operability.



**Ecological hazard
(the environment)**

Due to use of substances representing an inherent danger to health of environment.



**Safety Provisions
(persons & goods)**

Safety provisions in dangerous situation caused by misuse, inaccurate adherence to instruction or prescribed work routine.

General Guidelines

- In addition to the information contained in this manual, generally applicable legal provisions for Safety and Prevention of accidents must be adhered to.
- Please go through the manual and the instructions contained herein carefully, even if you possess prior experience in operating similar ground cleaning equipment.
- Schedule some time for the careful and thorough perusal of the manual contents.
- The responsibility of all persons in the working area fall upon the operator of the machine.
- No persons, children included, should be allowed within the zone of danger.
- The warning and instruction plates attached to the machine carry important advice on safe operation of the machine.
- Lost or illegible stickers must be replaced at the earliest.
- Prior to operation of the machine, the operator must ensure that the machine and its working implements are in proper and safe operating condition.
- Machines with identified and known defects must not be used.
- It is important that operators and all persons likely to use the machine familiarize themselves with all accessories and controls, as well as their functions, before commencing operation.
- Adherence to the above general instructions will help avoid the operator from having to read the manual while operating the machine.

Safety During Machine Operation

- The machine is applicable for **WET** scrubbing only.
- Ground cleaning machines may be run by qualified personnel only.
- The machine may be used for cleaning surfaces such as tiles, smooth concrete, marble, etc.

SAFETY INSTRUCTIONS



- The machine is only suitable for use on the types of surfaces specified in the owner's manual.
- Protect the machine from frost or extremely low temperatures.
- Never scrub or vacuum explosive liquids, combustible / explosive dusts as well as acids and solvents. This includes diesel, petrol, kerosene, paints, paint thinners, heating oil etc which can generate explosive fumes on contact with the suction air. Acetone, undiluted acids and aggressive solvents must not be vacuumed as it may cause damage to the machine components and brooms.
- Do not scrub/vacuum burning or glowing debris.
- Do not scrub/vacuum in flooded and slushy areas.
- This machine must not be operated by persons (including children) with limited physical ability, sensoric/mental capabilities or lack of experience, unless such persons are supervised by the person in charge.
- Children should be prevented from playing with the machine.
- The operator must use the machine properly. The operator must consider the local conditions and must pay attention to third parties especially children when operating the machine.
- Never leave the machine unattended when the motor is running.
- The operator must leave the machine only after the motor has come to a complete standstill, parking brake applied and the key been removed.
- Prior to starting work, the operator has to check if the machine's safety devices are working properly.
- The operator must wear tight fitting clothes only. The operator should wear safety shoes only when operating or while carrying out maintenance work.
- When operating or while carrying out maintenance work the operator must wear tight fitting clothes and safety shoes only.
- Check the immediate surrounding prior to starting. Ensure sufficient visibility.
- The operator must always use safety gloves, safety helmet, shoes while operating/maintaining the machine.
- On inclined/tilted surfaces, the tilt angle and the driving direction should not exceed the values given in this manual.
- Do not place any tool or metallic object on top of the battery. There is a risk of short circuit and deflagration.
- Smoking or naked flames are strictly prohibited.
- Always allow the machine sufficient time to cool before carrying out any repair or maintenance work.
- Do not place your hand or any object while the brushes are running.
- Suitable tools must be used for cleaning and maintenance work.
- Do not carry out any welding, drilling, sawing or grinding work on the frame sections. Damaged parts may be changed only at an authorized service center.
- It is not permitted to use aggressive and corrosive cleaning agents.
- Used batteries with the recycling symbol must not be disposed off household waste.
- Maintenance work may be carried out by authorised personnel/dealer only.
- Always use appropriate tool and equipments while working on the machine.
- Disconnect the battery when working on electrical system.
- Battery may be handled and changed only by skilled maintenance personnel.
- Pay attention that the insulation of the charger cable is not damaged.
- The cable must not chafe against anything. In the case of defective insulation, do not use the charger.
- When charging the batteries, there must be sufficient ventilation in the charging area. Otherwise, there is a risk of explosion.
- Batteries must not be connected or disconnected when conducting electricity.

SAFETY INSTRUCTIONS

Spare Parts & Accessories:

WARNING

Use accessories and spare parts which have been approved by the manufacturer. The exclusive use of original accessories and original spare parts ensures that the machine can be operated safely and trouble free.

Equipments with Rotating Brushes:

- Use only brushes that are provided with the machine or specified in the Operations Manual. The use of other brushes can affect the safety of the machine.

DANGER - Do Not Scrub Or Vacuum:
**Corrosive/Battery Fluids/Explosive/Flammable/
Magnetic/Radio-active/Biohazard Materials.**



Safety Gear:

As necessary



This machine is not suitable for evacuation of dusts, which are explosive or dangerous to health.

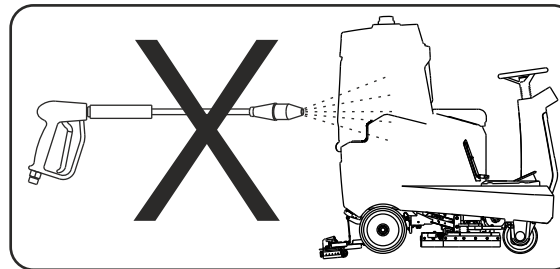

DO NOT CLEAN THE MACHINE BY MEANS OF VAPOUR JET OR HIGH PRESSURE CLEANING EQUIPMENT.



- Do not smoke near machine.

- Do not expose machine to open flames or burning debris.



The machine may be used only on indoor hard floorings and for operation on level grounds with a maximum inclination of up to 10°.

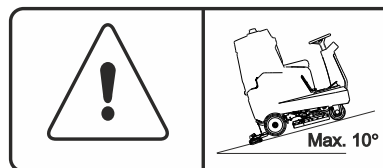





- The machine is splash-water proof (IPX3).
- This machine is not intended for use on public roads and places. Only qualified personnel must perform maintenance and repair work.

SAFETY INSTRUCTIONS

SYMBOL & HAZARD PICTORIAL DEFINITIONS

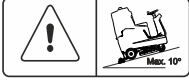

 <p>Read the Operator's Manual</p>	 <p>General Warning</p>	 <p>Caution</p>	 <p>Ecological Hazard</p>	 <p>Toxic Hazard</p>
 <p>Max. Inclination</p>	 <p>Do Not Use High Pressure Jets</p>	 <p>Remove Key</p>	 <p>Unplug Battery</p>	 <p>Max. Water Wading</p>
 <p>Do Not Tamper</p>	 <p>Electrical Hazard</p>	 <p>No Smoking</p>	 <p>No Open Flames</p>	 <p>Recycle</p>
 <p>Deep Clean Mode</p>	 <p>Safety Gear</p>	 <p>Store Indoors</p>	 <p>Keep away from rodents & Insects</p>	 <p>Corrosion Hazard</p>

SAFETY INSTRUCTIONS

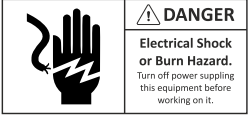

SYMBOL & HAZARD PICTORIAL DEFINITIONS

 <p>Stop</p>	 <p>Shock Hazard</p>			

SAFETY INSTRUCTIONS



ENVIRONMENTAL RESPONSIBILITY



The packaging material can be recycled. Please do not place the packaging into the ordinary refuse for disposal, but arrange for the proper recycling.



Old machines contain materials that can be recycled. Please arrange for the proper recycling of old machines. Batteries and actuators contain substances that must not enter the environment. Please dispose off your old machines, batteries and actuators using appropriate collection systems.



KNOW YOUR MACHINE

KNOW YOUR MACHINE

Main Components of the Machine:

(Standard & Premium versions)

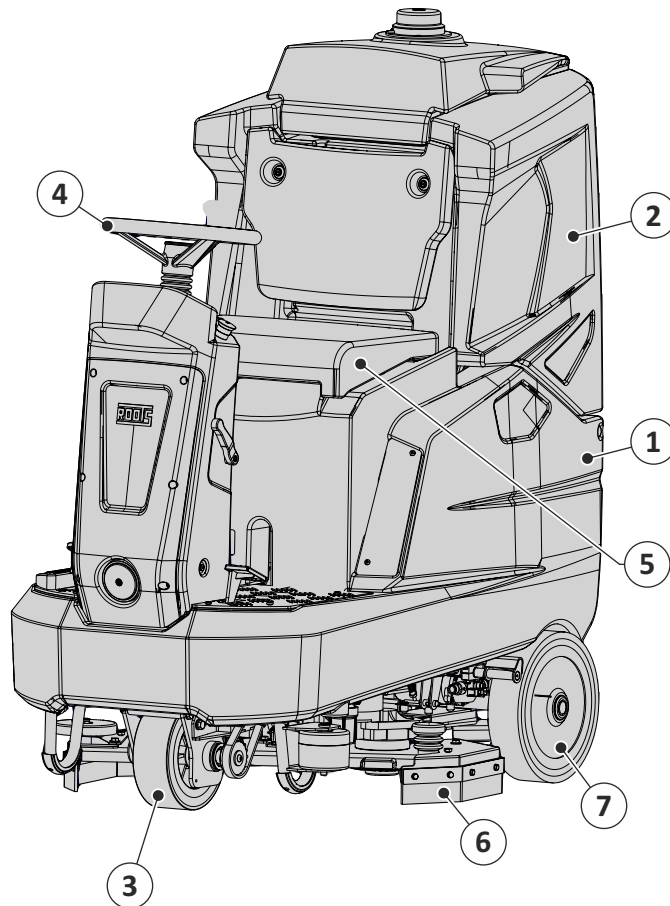

- 1. Fresh water tank
- 2. Dirty water tank
- 3. Traction motor
- 4. Steering wheel
- 5. Operator seat
- 6. Brush head

- 7. Rear wheel
- 8. Vacuum motor housing
- 9. Dirty water drain hose
- 10. Fresh water drain
- 11. Squeegee holder

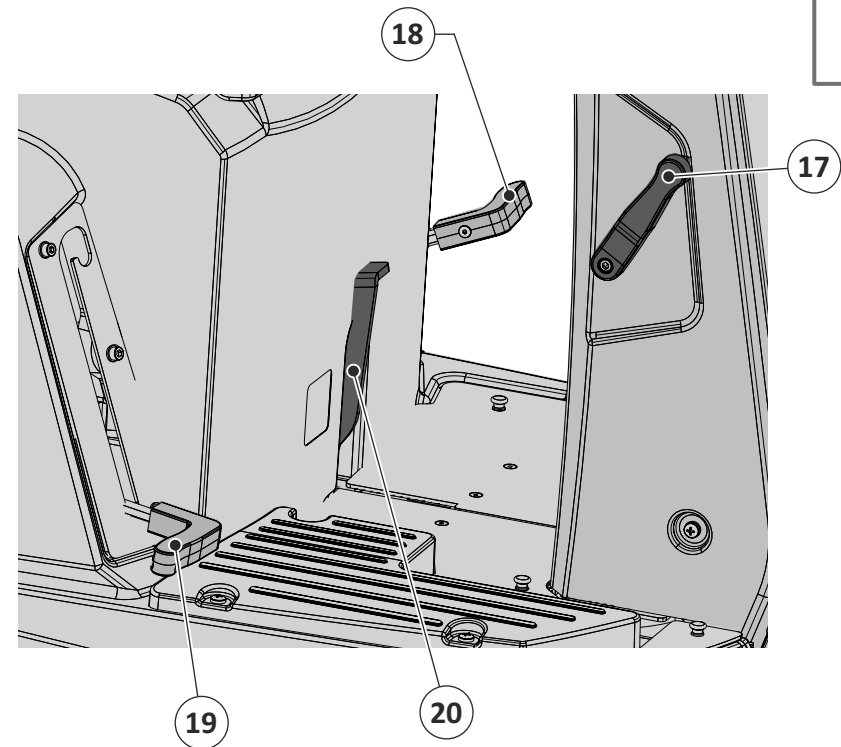
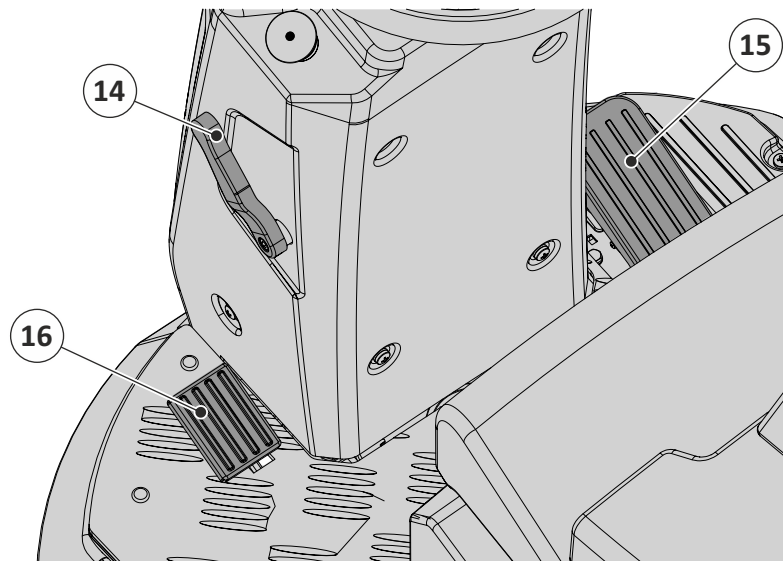
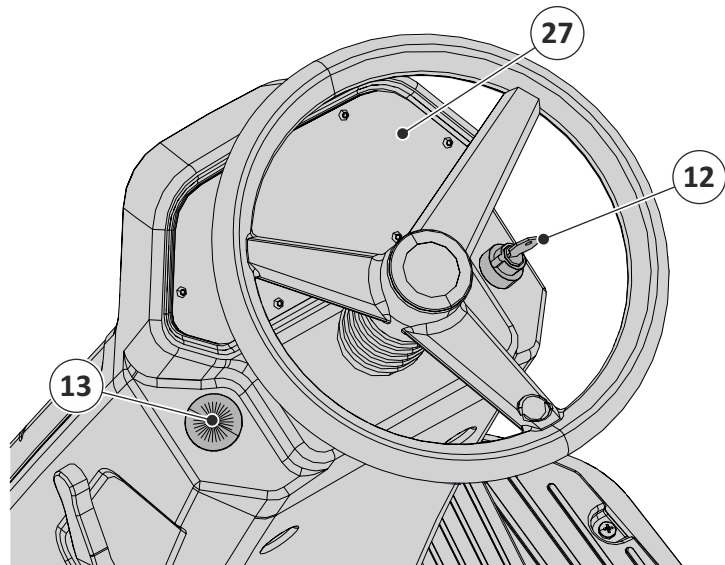

- 12. Key switch
- 13. Emergency stop switch
- 14. Parking brake lever
- 15. Accelerator pedal
- 16. Brake pedal
- 17. Water flow control lever *(for std version)*
- 18. Squeegee raise/lower lever *(for std version)*
- 19. Brush head raise/lower lever *(for std version)*
- 20. Extra pressure pedal *(for std version)*

KNOW YOUR MACHINE

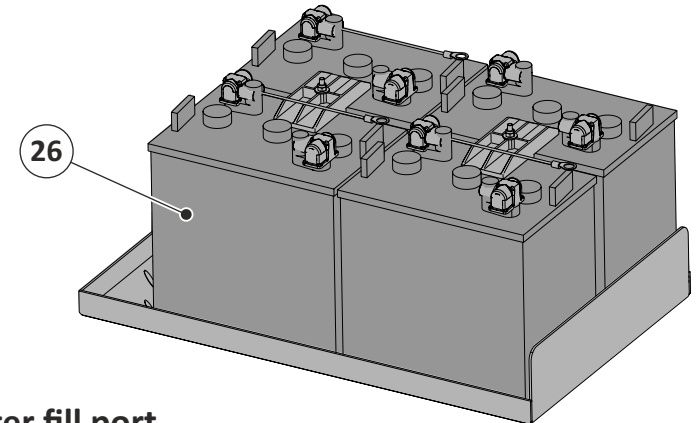
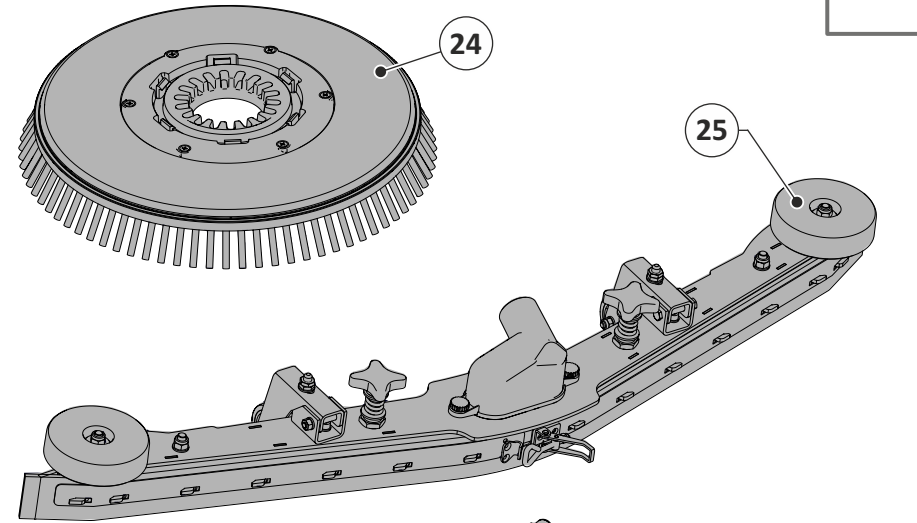
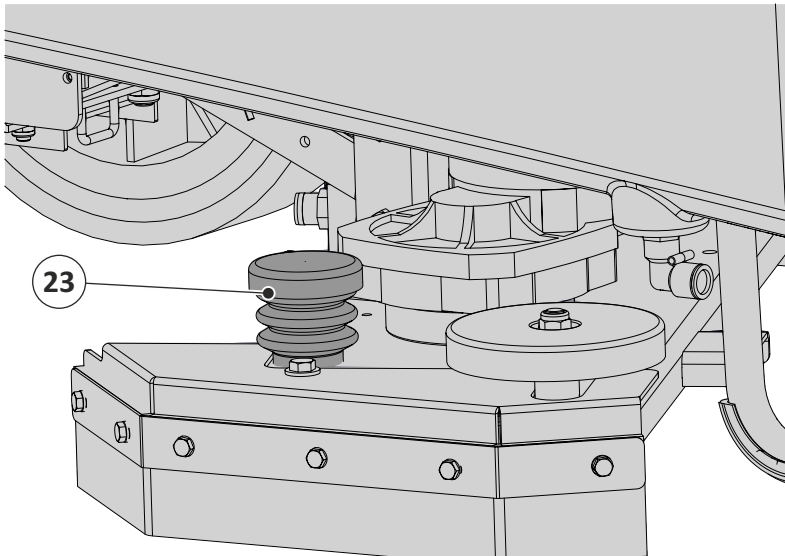
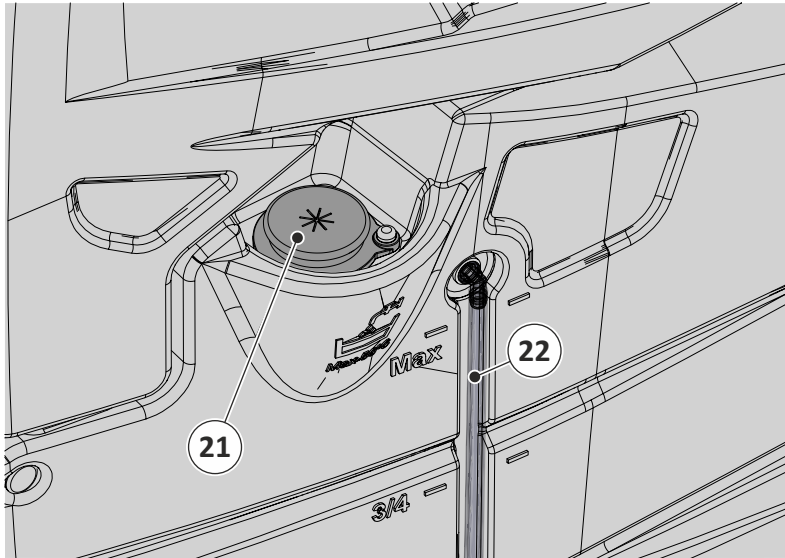

- 21. Fresh water fill port
- 22. Fresh water level indicator
- 23. Brush release pedal
- 24. Brush
- 25. Squeegee
- 26. Battery
- 27. Control panel

KNOW YOUR MACHINE - DECALS

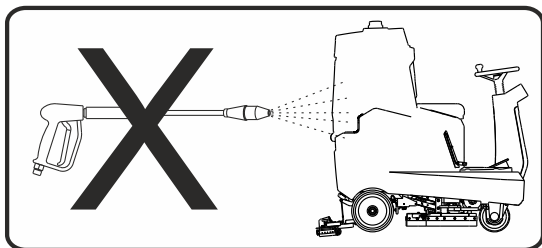

(1)

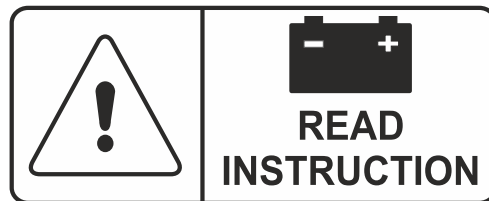

(2)

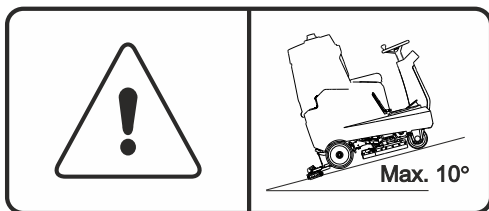

(3)

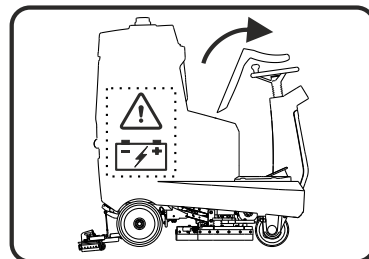

(4)

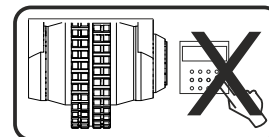

(5)



(6)

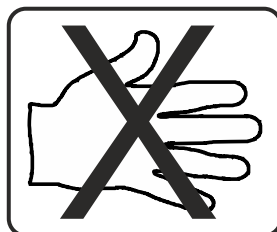

(7)

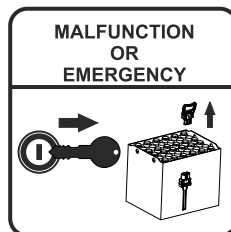

(8)

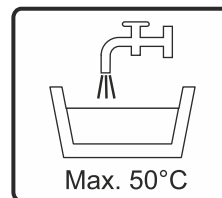

(9)



(10)

1. Do not clean machine with high pressure jet machine.
2. Read battery instructions.
3. Maximum inclination warning.
4. Battery charging instruction.
5. Do not tamper with drive motor settings.
6. Read Operator's Manual
7. Do not insert hand - Crush hazard.
8. Remove key in case of malfunction or emergency.
9. Maximum water temperature for fresh water tank.
10. Extra pressure.



WORKING PRINCIPLE

Working Principle

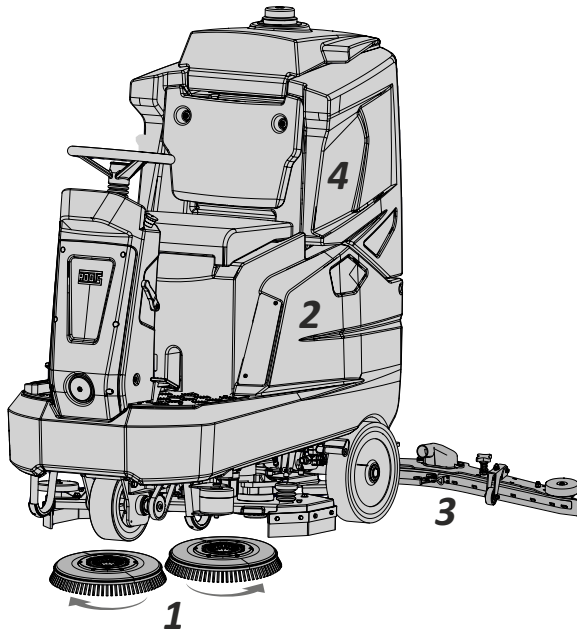

A squeegee and suitable brushes or pads are required for wet cleaning of hard floorings. The rotating brushes (1) scrubs the floor thoroughly, removing dirt, by cleaning agent supplied from the fresh water tank (2) thereby cleaning the floor. The soiled water is drawn during the same cycle through the squeegee (3) and fed into the dirty water tank (4). Thus, the floor can be walked on immediately after it is dry and clean.

Useful Tips:

- Prior to wet cleaning, it is necessary to clean the floor. This way, not only is the cleaning efficiency improved, but wear and tear of the brush is also substantially reduced.
- If floors are particularly dirty or if wax has to be removed (basic cleaning); the floor must be treated twice.
- During the first cycle, the floor is scrubbed with the cleaning agent selected according to the degree of dirt encountered, the squeegee remaining lifted.
- Allow the cleaning agent to act on the floor for approx. 5 or 10 minutes, complying with the manufacturer's instructions.
- Scrub the floor once again while the squeegee is lowered.
- Too much foam indicates excessive dosage or improper suitability of detergent for the existing kind of dirt.
- Detergent particles contained in the soiled water that are not used will cause formation of foam.
- Instructions for dosage are given on the detergent tank and must ideally adhere to manufacturer's recommendations.
- The ideal type of detergent and the perfect dosage applicable to it will come through sustained use of the machine.

NOTE:

Comply with instructions for correct dosage of detergent. Correct dosage will help optimize costs and also minimize impact on the environment. Too much foam can affect the performance of the machine.





CONTROLS



Control Elements:

Control Panel - Standard Version

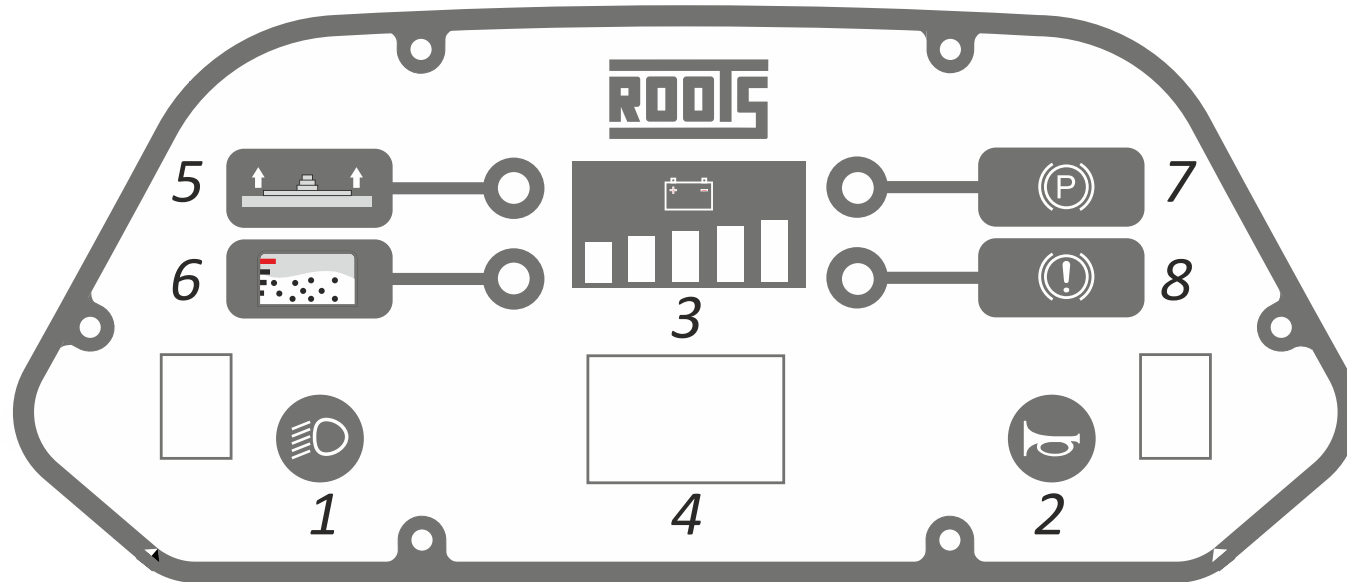

1. Headlamp switch
2. Horn switch
3. Battery charge indicator
4. Hour meter
5. Squeegee error indicator
6. Dirty water tank full indicator
7. Parking brake engaged indicator
8. Fault indicator

CONTROLS



Control panel functions in detail:

1. Headlamp Switch:



To activate the headlamp, first turn ON the key switch, then press the switch once to switch ON the headlamp, press the switch once again to turn OFF the headlamp.

2. Horn Switch:



To activate the horn, first turn ON the key switch, then press the switch once to honk.

3. Battery Charge Indicator LED:



The battery charge indicator has five LED's to show the charge in the battery. When all five LED's are lit, the battery is at full capacity. When only one LED is lit, the battery is drained and has to be recharged for further use.

4. Hour meter:

The hour meter displays the total number of hours the machine has been used.

5. Squeegee Error Indicator LED:



The squeegee error indicator LED glows when the squeegee is not raised during reverse travel of the machine. The LED indicator is accompanied by an audible warning also. The LED goes OFF when the squeegee is raised and then reversed.

6. Dirty Water Tank Full Indicator LED:



The dirty water tank full indicator glows when the dirty water tank has reached its maximum capacity. The light goes OFF when the dirty water tank is drained or is empty.

7. Parking Brake Error Indicator LED:



The parking brake error indicator LED glows when the parking brake is engaged. This is to warn the operator to disengage the parking brake before operating the machine.

8. Fault Indicator LED:



The fault indicator LED glows when there is any fault in the machine's systems. In the event of the LED being activated, it is recommended to call the service engineer for rectification.

CONTROLS



Control Elements:

Control Panel - Premium Version

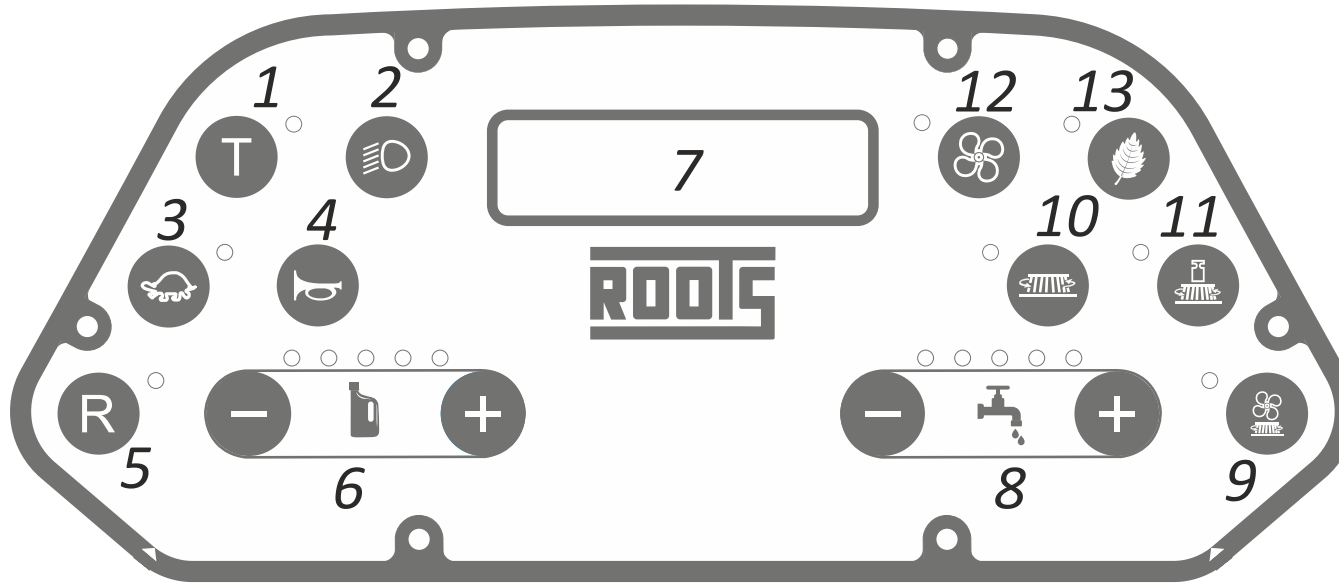

1. Transport mode switch

2. Headlamp switch

3. Speed control switch

4. Horn switch

5. Reverse mode switch

6. Dosing control switch

7. LCD panel

8. Fresh water control switch

9. AUTO mode switch

10. Brush motor On/Off switch

11. Extra pressure On/Off switch

12. Suction turbine On/Off switch

13. ECO mode switch

CONTROLS



Control panel functions in detail:

1. Transport Mode Switch:



Press the switch once to enable the transport mode function. In this mode all scrubbing and vacuuming systems will be deactivated, only traction functions will be enabled. Can be used when scrubbing is interrupted or to travel over humps, ramps.

2. Headlamp Switch:



To activate the headlamp, first turn ON the key switch, then press the switch once to switch ON the headlamp, press the switch once again to turn OFF the headlamp.

3. Speed Setting Switch:



Upon initial startup of the machine the speed is set to FAST. To change the speed to SLOW press the switch once, the LCD panel will display "SLOW". To change the speed to FAST press the switch again, the LCD panel will display "FAST".

SLOW

FAST

4. Horn Switch:



To activate the horn, first turn ON the key switch, then press the switch once to honk.

5. Reverse Mode Switch:



Press the switch once to enable the reverse mode function. In this mode all scrubbing and vacuuming systems will be deactivated, the machine will move only in reverse direction. Press the switch once again to resume scrubbing operations in forward direction.

6. Dosing Control Switch:



Press -/+ to decrease or increase the quantity of cleaning chemical. A blue LED glows on top of the switch to visually inform the operator about the selected level. This mode will work only when the brush head is activated.

CONTROLS



7. LCD Panel:



The LCD panel displays all the functions of the machine including total hours run and battery charge capacity. The LCD panel is backlit to enable the operator to view the messages clearly in all working conditions.

8. Fresh Water Flow Control Switch:



Press -/+ to decrease or increase the quantity of fresh water. A blue LED glows on top of the switch to visually inform the operator about the selected level. This mode will work only when the brush head is activated.

9. AUTO Mode Switch:



The AUTO mode is a one touch function which activates all the pre-set scrubbing parameters selected by the operator.

10. Brush Motor On/Off Switch:



Upon first press the brush motor gets pre-selected, when the accelerator pedal is pressed the brush head lowers downwards with the brushes rotating midway. Upon second press of the switch, the brush motors stop and the brush head is retracted.

11. Extra Pressure On/Off Switch:



The extra pressure function will work only when the brush motors are in operating condition. Press and hold the switch to use the deep cleaning function (actuator extends completely), when the switch is released the brush head returns to its normal operating position.

12. Suction Turbine On/Off Switch:



Press the switch once to switch ON the suction turbine, at the same time squeegee also lowers. Press for the second time to turn OFF the vacuum motor with a delay of 15 seconds, squeegee is raised immediately.



13. ECO Mode Switch:



The ECO mode acts as a battery saver. When the ECO mode switch is pressed the voltage to the brush motor and suction turbine is reduced. This mode not only acts as a power saver but also reduces the noise output from the machine.

CONTROLS



LCD Panel Display Nodes *(for premium version only):*



The LCD panel displays all the functions of the machine including total hours run and battery charge capacity. The LCD panel is backlit to enable the operator to view the messages clearly in all working conditions.

The display messages are listed below:

Machine power-up:

RB650	BATTERY TYPE: LEAD 0000_0000_0000
A1 ASSEMBLY: 0000 A1 FIRMWARE: 0000	A2 ASSEMBLY: 0000 A2 FIRMWARE: 0000
A3 ASSEMBLY: 0000 A3 FIRMWARE: 0000	FAST 00:00

2. Head lamp ON/OFF:

HLIGHT ON	HLIGHT OFF
-----------	------------

Horn ON/OFF:

HORN ON	HORN OFF
---------	----------

Forward/Reverse:

REVERSE	FORWARD
---------	---------

Brush ON/OFF:

BRUSH ON	BRUSH OFF
----------	-----------

Vacuum ON/OFF:

VACUUM ON	VACUUM OFF
-----------	------------

Auto Mode ON/OFF:

AUTO MODE FAST	AUTO MODE SLOW
-------------------	-------------------

Extra Pressure ON/OFF:

EXTRA PRESSURE ON	EXTRA PRESSURE OFF
----------------------	-----------------------

CONTROLS

LCD Panel Display Nodes (for premium version only):

Water Pump:

WATER PUMP OFF	
WATER PUMP LOW	
WATER PUMP LOW-MED	
WATER PUMP MED	
WATER PUMP MED-HIGH	
WATER PUMP HIGH	

Dosing Pump:

DET PUMP OFF	
DET PUMP LOW	
DET PUMP LOW-MED	
DET PUMP MED	
DET PUMP MED-HIGH	
DET PUMP HIGH	

Speed:

SLOW	FAST
------	------

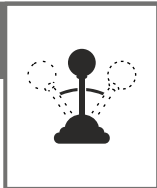

CONTROLS



LCD Panel Display Nodes *(for premium version only):*

ECO Mode ON/OFF:

ECO ON
FAST

ECO OFF
SLOW

Transport:

TRANSPORT

Battery level indicator:



All bars - 100% capacity



Two bars - 20% capacity

Hour meter:

00:00

Dirty water tank full:

 TANK
FULL

Error Codes Messages:

E01 - Fuse Blown:

E01 - FUSE BLOWN

E03 - A2 TOP Error:

E03 - A2 TOP ERROR

E04 - No CAN communication:

E04 - NO
CAN COMMUNICATION

E09 - POT not functioning:

E09 - POT
NOT FUNCTIONING

E10 - Release accelerator pedal:

E10 - RELEASE
ACCELERATOR PEDAL

E11 - A3 TOP error:

E11 - A3 TOP ERROR

CONTROLS



LCD Panel Display Nodes *(for premium version only):*

E12 - Drive motor over load:

E12 - DRIVE
MOTOR OVERLOAD

E13 - Over voltage:

E13 - OVER VOLTAGE

E14 - Brake/Seat switch open:

E14 - BRAKE/
SEAT SWITCH OPEN

E15 - Crippled machine transport switch:

E15 - CRIPPLED MACHINE
TRANSPORT SWITCH

E16 - Charge the battery:

E16 - CHARGE
THE BATTERY

E18 - Motor setting error:

E18 - MOTOR
SETTING ERROR

E19 - SD card unavailable:

E19 - SD CARD
UNAVAILABLE

E20 - SD card fail:

E20 - SD CARD
FAIL

E21 - 8701 Fault:

E21 - 8701
FAULT

E22 - Brush motor short circuit:

E22 - BRUSH
MOTOR SHORT CIRCUIT

CONTROLS

Control Levers (standard version):

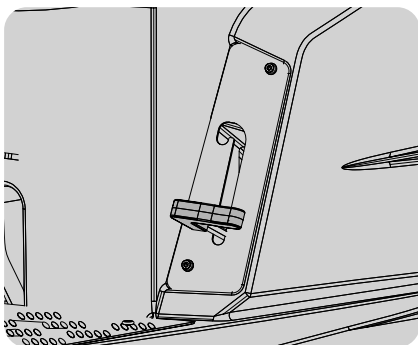

Squeegee Raise/Lower Lever:

This lever is located on the left hand side of the machine. Pull the lever upwards to raise the squeegee. Push the lever downwards to lower the squeegee.

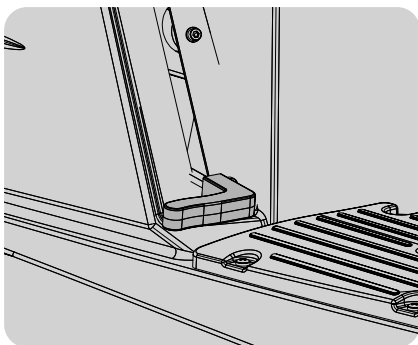

Brush Head Raise/Lower Lever:

This lever is located on the right hand side of the machine. Pull the lever upwards to raise the brush head. Push the lever downwards to lower the brush head.

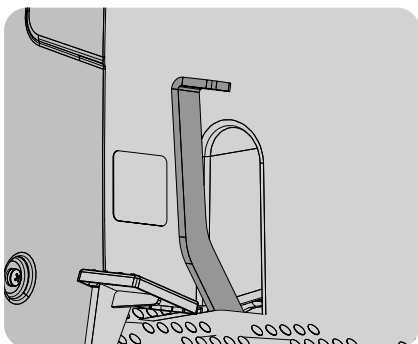

Extra Pressure Engage/Disengage Lever:

This lever is located behind the steering pillar between the driver's seat. Push the lever downwards and hold to engage the extra pressure (brush head is lowered completely). The brush head return's to its normal operating position when the foot is taken off the pedal.



Note: Do not press the pedal when the brush head is in lifted position.

Steering Wheel:

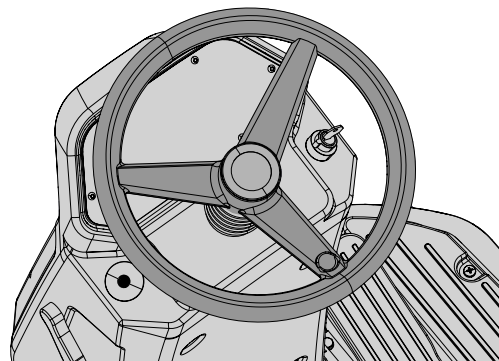

The steering wheel is used to turn the machine in left or right direction of travel.

Accelerator Pedal:

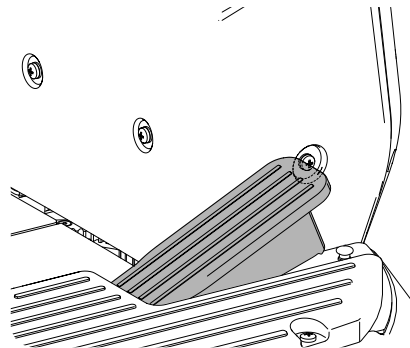

The accelerator pedal is located on the right hand side of the floor panel. It is used to control the speed of the machine during transport and scrubbing modes. A foot rest is provided for easy operation of the pedal.



CONTROLS



Brake Pedal:

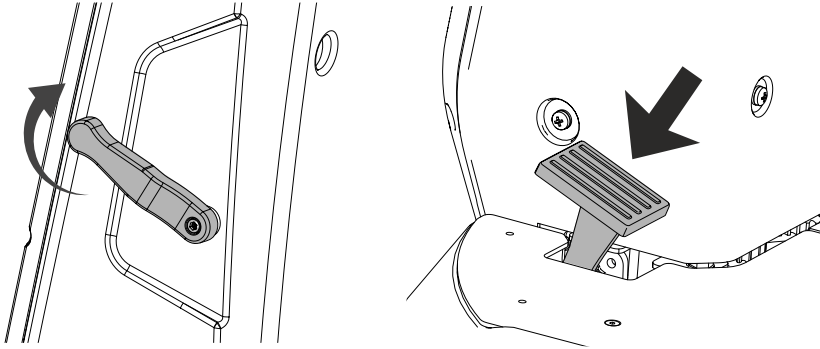

The brake pedal is located on the left hand side of the floor panel. It is used to reduce/stop the speed of the machine during transport and scrubbing modes. The brake pedal has an inbuilt parking function. To activate the park brake, press the brake pedal till it locks with a click sound. To disengage the parking brake press the brake pedal downwards.



MACHINE OPERATION

MACHINE OPERATION

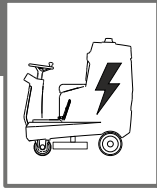

Machine Operation:

It is the operator's responsibility to be knowledgeable of all potential operating hazards and to take every reasonable precaution to ensure safety of oneself, others, animals, and property.

This section of the Operator's Manual is designed to familiarize, instruct, and educate safe and proper machine use to the operator. The operator must be familiar with the machine operation and all associated safety practices before operating.

Proper operation of the machine, as detailed in this manual, will help ensure years of safe and satisfactory use of the machine. **READ, UNDERSTAND, and FOLLOW** the safety messages. Serious injury or death may occur unless care is taken to follow the warnings and instructions stated in the safety messages. Always use good common sense to avoid hazards.

	WARNING
Do not operate a damaged or malfunctioning machine. Risk of equipment failure or cause of injury or death or damage to property.	

Operator Requirements:

Only qualified people are allowed to operate the machine. A qualified operator has to read and understand the owner's manual and should comply with its procedures. If any part of the operation and safe use of this equipment is not completely understood, consult an authorized dealer for a complete explanation.

If the operator cannot read the manual for himself or does not completely understand the operation of the equipment, it is the responsibility of the supervisor to read and explain the manual, safety practices, and operating instructions to the operator.

Employer Responsibilities:

- Train the employee to operate the machine in a safe way.
- Permit only qualified personnel to operate and service the machine.
- Instruct all operators to maintain the shields and guards in its proper working condition at all times.
- Ensure that the operators use approved Personal Protective Equipment at all times or whenever required.
- Forbid the operators to carry additional people on the truck or the machine.
- Ensure that nobody including the operator modifies or alters the machine or any of its function, doing so may cause fatal injury or death or it may damage the machine itself.
- Ensure that children do not operate the machine.

Before Starting the Machine:

Before operating the machine, ensure that the equipment is working properly and that you are prepared for cleaning operations by checking the Pre-Operative Checklist and testing the machine functions.

MACHINE OPERATION

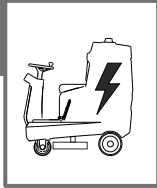

Machine Operation

This section describes on how to use the machine under the following sections:

- PRE-SCRUBBING CHECKPOINTS
- DRIVING THE MACHINE
- FILLING OF FRESH WATER
- WATER LEVEL SETTING
- INSTALLATION/REMOVAL OF BRUSHES
- INSTALLATION/REMOVAL OF SQUEEGEE
- RAISING/LOWERING OF BRUSH HEAD
- RAISING/LOWERING OF SQUEEGEE
- BRUSH & PAD INFORMATION
- SCRUBBING PROCEDURE
- END OF SCRUBBING
- DRAINING OF TANKS
- CLEANING THE MACHINE

PRE-SCRUBBING CHECKPOINTS:

- Check for any exterior damage to the machine.
- Check the squeegee for damage.
- Check the brushes for damage.
- Check the battery charge levels.
- Check for any error warning.
- Check for leaks in the tanks.
- Check the area to be cleaned is free from any hazardous chemical or other substance.
- Check whether the dirty water tank is empty and clean.
- Check the float and limit switch for free movement.
- Check if water reaches the floor.
- Check whether the right brushes are equipped for the floor type.
- Check whether the squeegee knobs are in position.

Worksite:

- Ensure that there are no flammable materials in the vicinity of the machine during the scrubbing operation.

Start-Up Test:

By identifying any problem before traveling to the worksite, you'll save unnecessary travel time and will be able to make repairs more easily with the proper tools.

Driving in/around worksite:

Always follow the rules and regulations of the worksite while driving the machine.

When approaching downgrades, select the proper speed and use the brakes as required to maintain safe descent speed without over-speeding.

MACHINE OPERATION

DRIVING THE MACHINE:

Driving (for standard version):



1. Sit in operator seat.

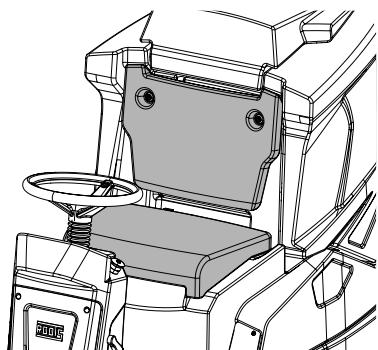

The operator seat has a safety switch to prevent the machine from starting inadvertently. Sit firmly on the seat. Release the *Emergency Stop Switch* if activated.

2. Insert key into key switch.

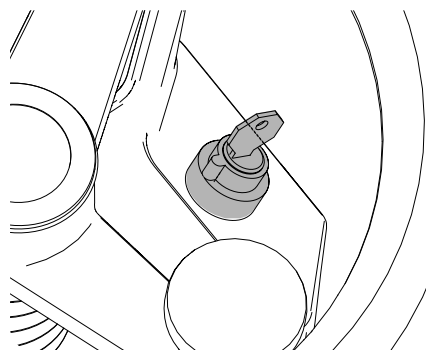

The key switch is located on the right hand side of the machine in the control panel. Insert the key and turn it clockwise once to power up.

3. Release parking brake.

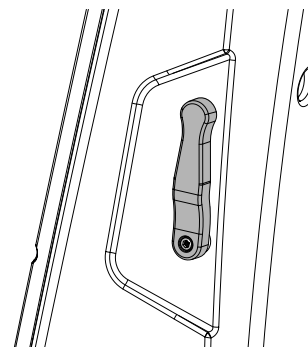

Parking brake engaged

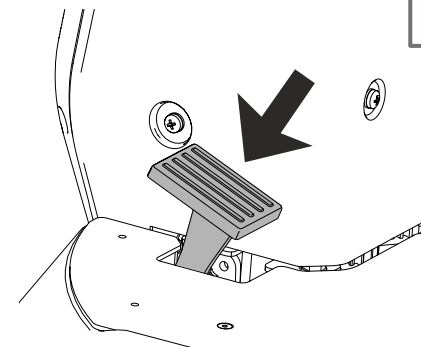

Parking brake disengaged

To disengage the parking brake, push the brake pedal downwards till the brake is released. The LED on the control panel goes OFF.

Both (P) & (!) LED's go OFF.

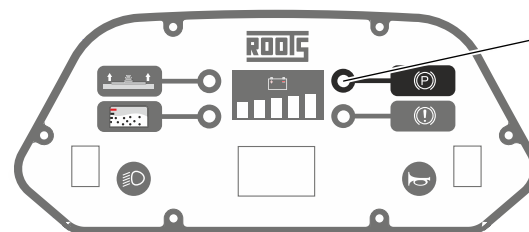

Parking Brake LED

4. Select direction of travel.

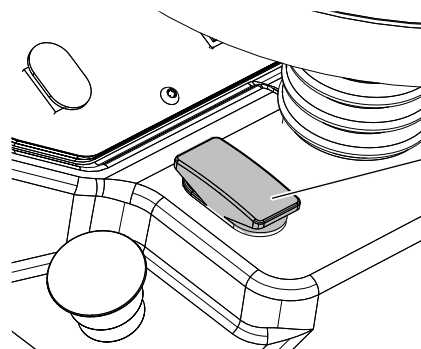

Forward & Reverse Switch

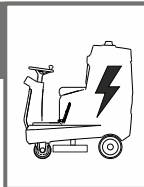

MACHINE OPERATION

The forward & reverse switch (FNR) is located on the left hand side of the machine on the control panel. It is a three position switch.

F - Forward - Push the switch upwards.

N - Neutral - Switch will be in middle position.

R - Reverse - Push the switch downwards.

Select the required switch position depending on the direction of travel.

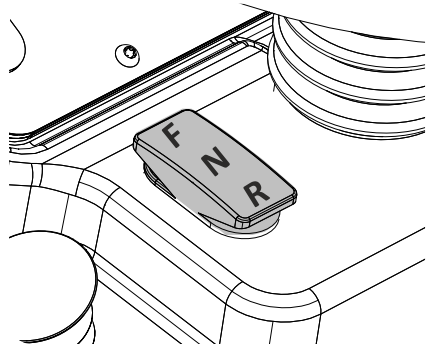

5. Press the accelerator pedal.

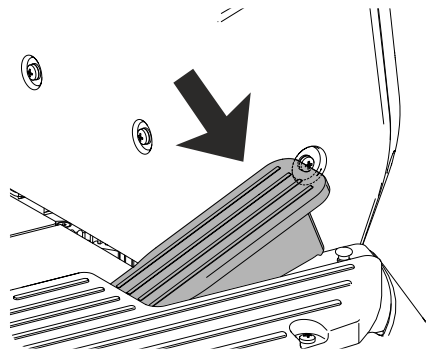

Press the accelerator pedal downwards gently to propel the machine in either forward or reverse direction depending upon the switch position.

The speed of the machine will vary according to the degree of the pedal pressed.

6. To slow down, release the accelerator pedal gently. To stop the machine press the brake pedal.

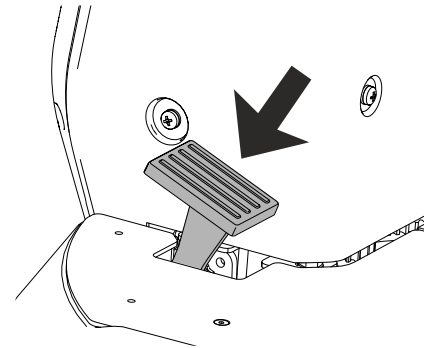

WARNING: Do not press the brake pedal simultaneously while the accelerator pedal is operated. It will cause damage to the drive system.

Driving on Inclined Surfaces:

- ☞ Drive slowly on downhill/uphill, on turns, wet grounds, ramps.
- ☞ Do not make sharp turns: machine might tip over.
- ☞ Do not drive with the tank in open position.
- ☞ Do not park the machine in slopes.
- ☞ Do not jack the machine in slopes.
- ☞ Do not go on a steep downhill with a full tank.

CAUTION: Exercise caution for oncoming vehicles and other equipments and stationary objects, people or animals.

7. Turn the steering wheel to the left or right depending upon the direction of travel.

CAUTION: DO NOT make sudden sharp turns at high speed, risk of machine tipping over, cause injury or damage to machine or property.

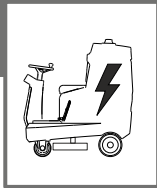

MACHINE OPERATION

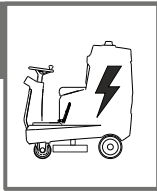

Safe Turn Feature:

The machine is equipped with a safety feature which slows the machine when a sudden sharp steering input is detected. This is to prevent the machine from tipping over. This is standard on all versions of the machine.

8. The machine is equipped with a LED headlamp for operating in dark or low lit areas.

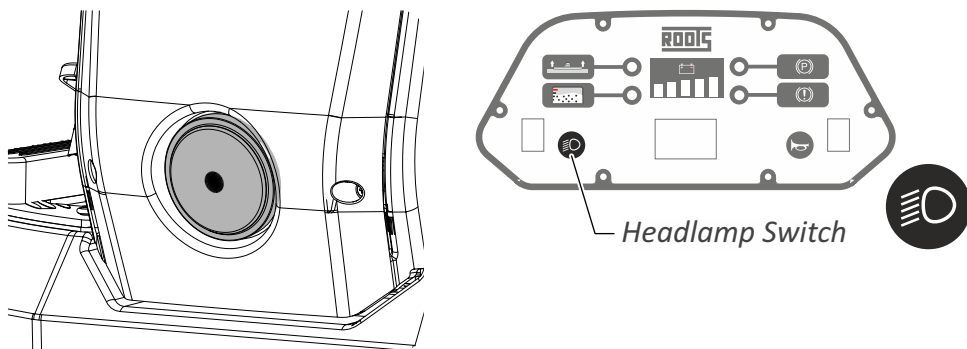

Turn the key switch to ON position. Press the headlamp switch once to turn ON the headlamp, press the switch once again to turn the headlamp OFF.

NOTE: Switch OFF the headlamp when not in use. Risk of battery drain.

9. Use the horn to warn by-standers or other vehicles in the vicinity of the machine.

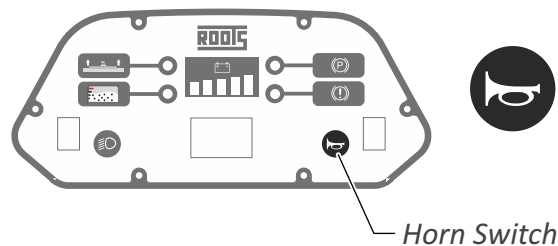

Squeegee Error During Reverse:

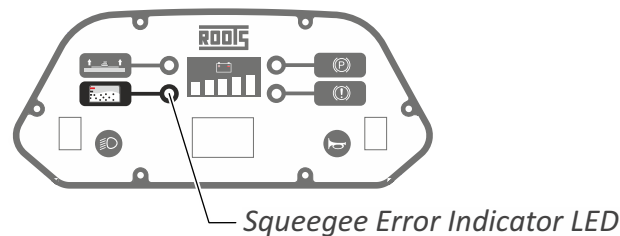

The squeegee error LED lights up when the machine is set in reverse mode, without the squeegee being raised.

Driving in Flooded Areas:

Extreme care should be taken when driving through flooded areas. Drive very slowly in a flooded area.

DO NOT drive through a flooded area beyond a depth of 5 mm. It may damage the drive motor.

It is also recommended that the operator avoids driving through a flooded area whenever possible.

DO NOT use the machine to collect flood water.

WARNING:
 **DO NOT DRIVE THROUGH A FLOODED AREA BEYOND A DEPTH OF 5 mm. IT MAY DAMAGE THE DRIVE MOTOR.**

MACHINE OPERATION

DRIVING THE MACHINE:

Driving (for premium version):



1. Sit in operator seat.

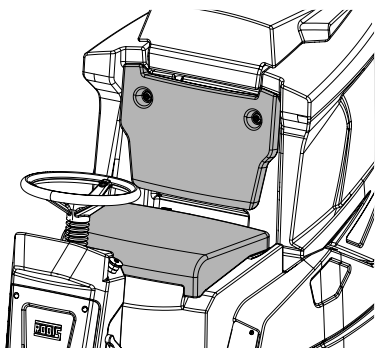

The operator seat has a safety switch to prevent the machine from starting inadvertently.

Sit firmly on the seat.

Release the *Emergency Stop Switch* if activated.

2. Insert key into key switch.

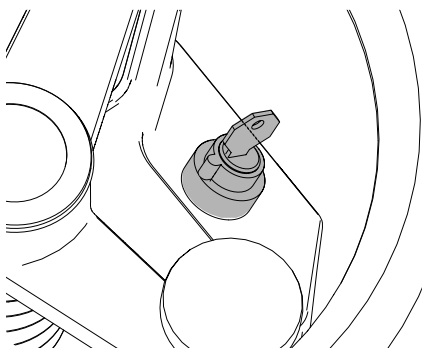

The key switch is located on the right hand side of the machine in the control panel. Insert the key and turn it clockwise once to power up.

3. Release parking brake.

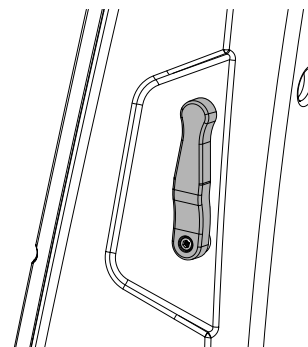

Parking brake engaged

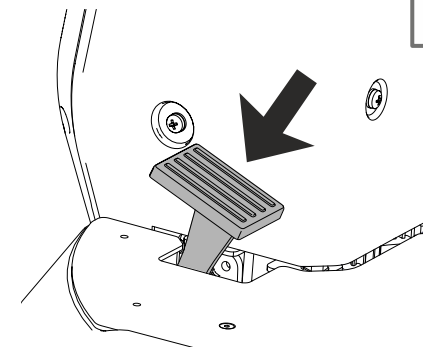

Parking brake disengaged

To disengage the parking brake, push the brake pedal downwards till the brake is released.

4. Select direction of travel.

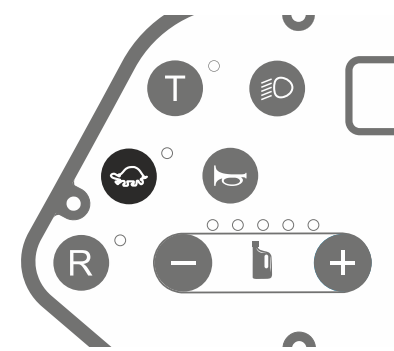
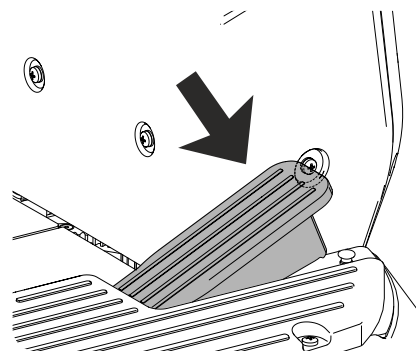

Upon start up the machine's speed setting will be in fast and the direction of travel will be in forward. Press the turtle symbol  to change the speed to slow. Press "R" switch once to travel in the reverse direction.

Note: All scrubbing and vacuuming functions will disengage during reverse function.

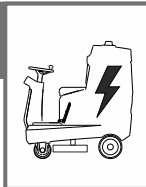

MACHINE OPERATION

5. To slow down, release the accelerator pedal gently. To stop the machine press the brake pedal.

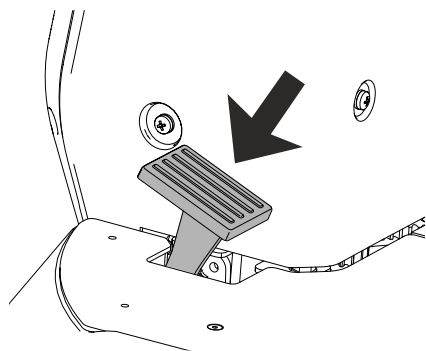

WARNING: Do not press the brake pedal simultaneously while the accelerator pedal is operated. It will cause damage to the drive system.

Driving on Inclined Surfaces:

- ☞ Drive slowly on downhill/uphill, on turns, wet grounds, ramps.
- ☞ Do not make sharp turns: machine might tip over.
- ☞ Do not drive with the tank in open position.
- ☞ Do not park the machine in slopes.
- ☞ Do not jack the machine in slopes.
- ☞ Do not go on a steep downhill with a full tank.

CAUTION: Exercise caution for oncoming vehicles and other equipments and stationary objects, people or animals.

Driving in Flooded Areas:

Extreme care should be taken when driving through flooded areas. Drive very slowly in a flooded area.

DO NOT drive through a flooded area beyond a depth of **5.0 mm**, it may damage the drive motor.

It is also recommended that the operator avoids driving through a flooded area whenever possible.

DO NOT use the machine to collect flood water.

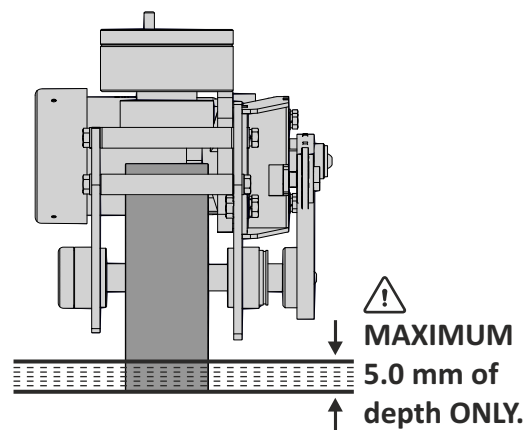

WARNING:
DO NOT DRIVE THROUGH A FLOODED AREA BEYOND A DEPTH OF 5 mm. IT MAY DAMAGE THE DRIVE MOTOR.

WARNING:
Do Not use the machine to push or tow other vehicles or equipments. Risk of machine damage.



MACHINE OPERATION

FILLING OF FRESH WATER:

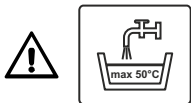

Fill only clean fresh water with Max. 50°C in the fresh water tank.

DO NOT fill dirty or contaminated water.

- **Bucket Filling** - Open the rubber cap located in the fresh water tank. Pull the cap upwards and slide out.

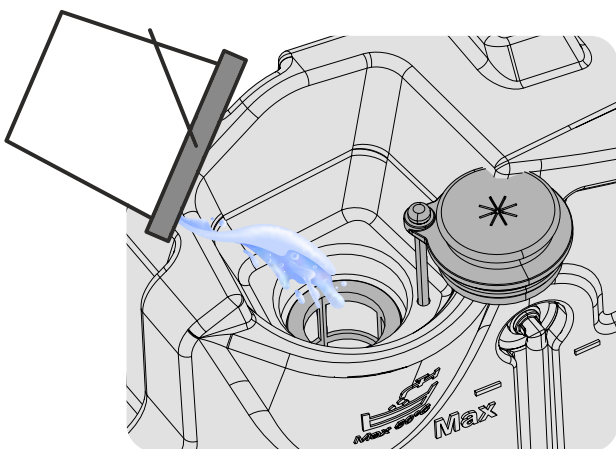
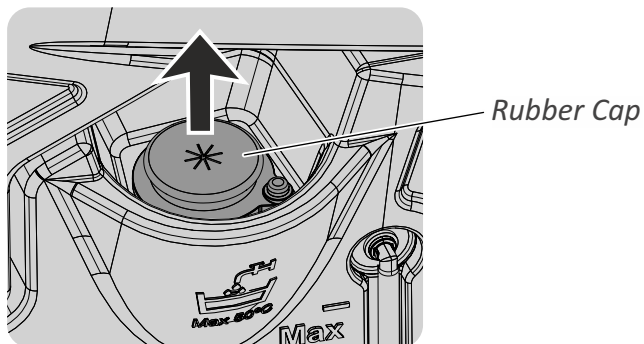

Water Level Hose

- Fill only fresh clean water through the strainer located inside the tank. Do not fill with water temperature beyond 50°C.
- The fresh water tank has a transparent hose with a float to indicate the level of fresh water inside the tank. Do not fill beyond the “Max” mark.

- **Hose Filling** - Insert the water hose into the rubber cap from the top side.
- Fill only fresh clean water through the strainer located inside the tank. Do not fill with water temperature beyond 50°C.
- The fresh water tank has a transparent hose with a float to indicate the level of fresh water inside the tank. Do not fill beyond the “Max” mark.

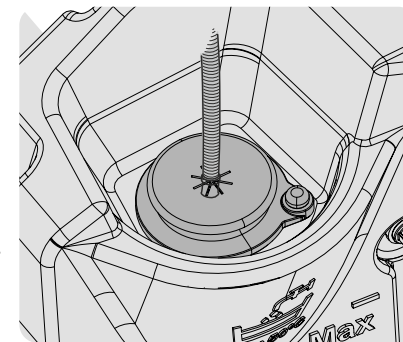

WARNING:

- × Do not remove the strainer and fill water.
- × Do not fill the tank with contaminated water.
- × Do not mix harsh acids and chemicals with the water.
- × Do not use heavy foaming chemicals.

Recommended detergents:

- ✓ Low foaming - **Roots Scrub Low Foam**



CAUTION:

Do not use household cleaning detergents or solutions. There is risk of dosing pump damage and poor scrubbing performance.

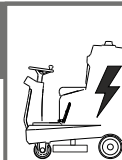

MACHINE OPERATION

WATER LEVEL SETTING:

For Standard Version:

The standard version of the machine uses a manual control system operated by a lever, located in the steering column, right hand side of the operator.

The lever has settings viz. "Max" & "0".

Position the lever between the values to get the desired amount of fresh water flow.

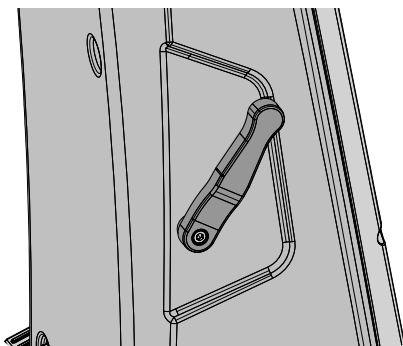
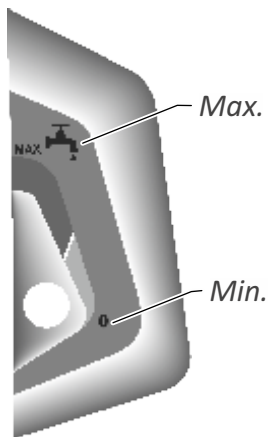

Max. water flow

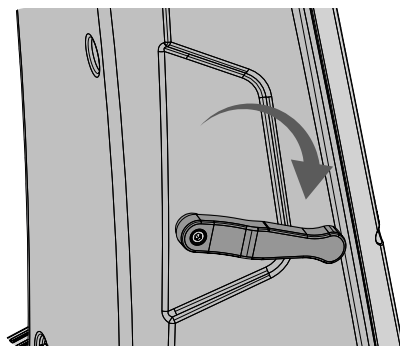

Min. water flow

WATER LEVEL SETTING:

For Premium Version:

The premium version of the machine uses an electronic control system operated by buttons in the control panel.

Press the "+" & "-" buttons on the control panel to increase or decrease the water flow. A series of LED's illuminate according to selection of water level.

The flow of water will vary according to the degree of pressure on the accelerator pedal.

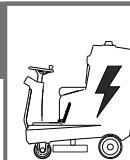

WATER PUMP OFF	
WATER PUMP LOW	
WATER PUMP LOW-MED	
WATER PUMP MED	
WATER PUMP MED-HIGH	
WATER PUMP HIGH	

MACHINE OPERATION

Chemical Dosing System (for premium version):

The premium version of the machine is also equipped with an intelligent chemical dosing system. This system is used to meter specified quantities of cleaning chemical or detergents depending upon the floor.

Press the “+” & “-” buttons on the control panel to increase or decrease the chemical/detergent flow. A series of LED’s illuminate according to selection of level.

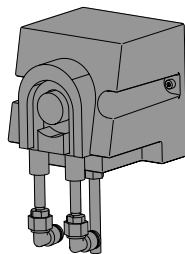

Dosing Pump



Dosing Tank

The dosing tank is located below the operator’s seat ahead of the battery pack.

To access the dosing tank open the operator seat. The dosing tank secures its contents using a spill proof cap.

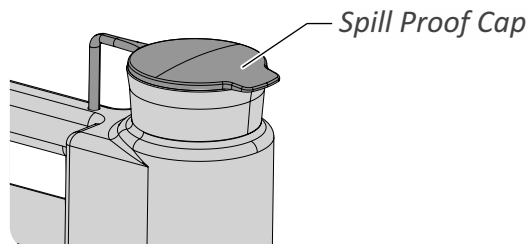

Spill Proof Cap

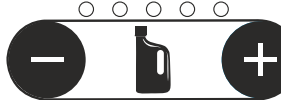
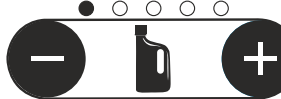
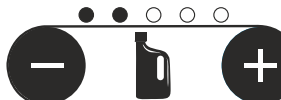
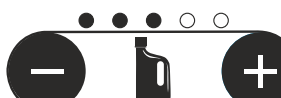
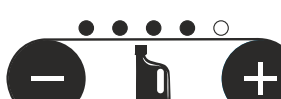
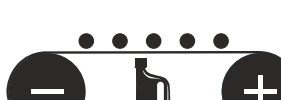
DET PUMP OFF	
DET PUMP LOW	
DET PUMP LOW-MED	
DET PUMP MED	
DET PUMP MED-HIGH	
DET PUMP HIGH	

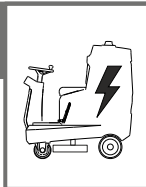

MACHINE OPERATION

INSTALLATION/REMOVAL OF BRUSHES:



The machine is equipped with a pair of disc brushes which are located in the brush head. The brush head is mounted onto the chassis of the machine, held by an actuator which facilitates up and down movement of the brush head during transport and scrubbing modes.

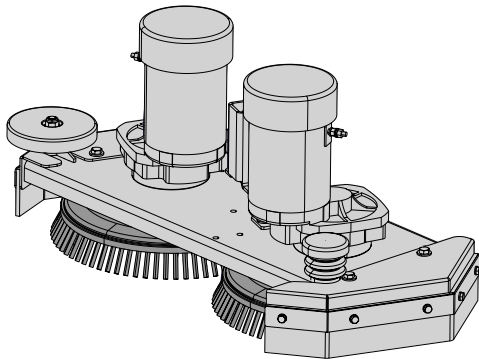

To remove the brush:

→ Ensure that the brush head is in raised position.

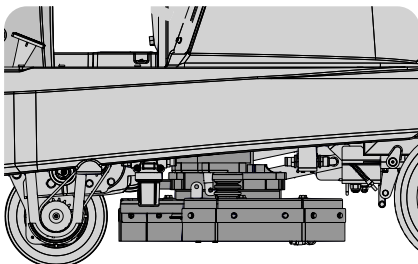

Floor

→ Press the brush release pedal downwards, the brush will drop down from its catch.

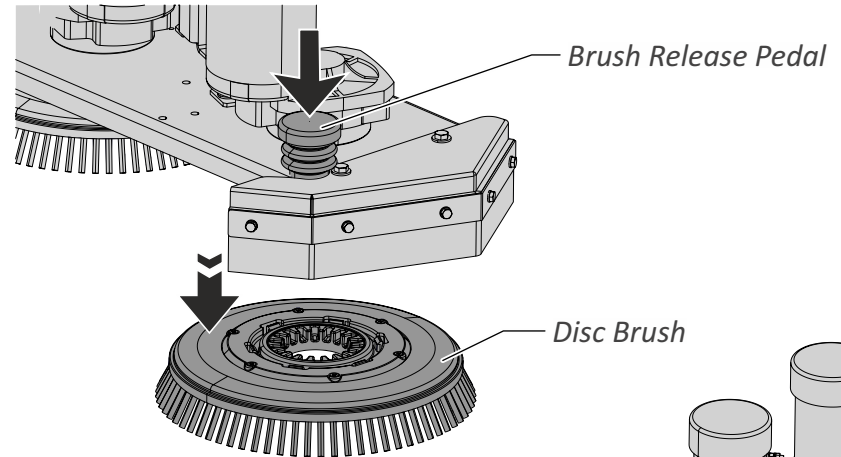

There are two brush release pedals located on either side of the brush head, one for each brush.

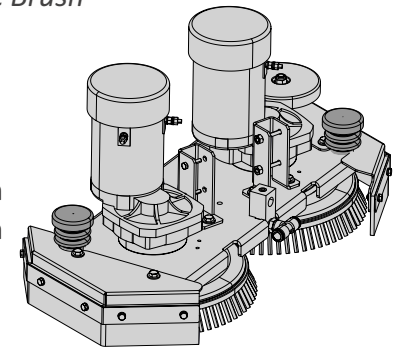

To install the brush:

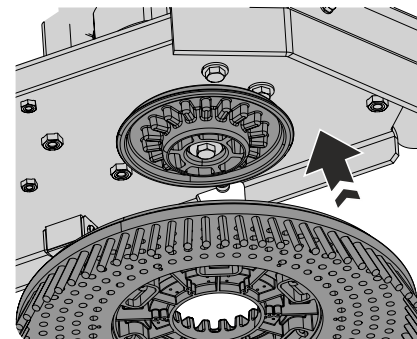

To install the brush to the brush head, align the slots provided in the brush catch to the catch holder in the machine. Push it upwards till it snap fits. Now the machine is ready for use.

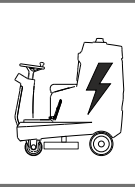

MACHINE OPERATION



INSTALLATION/REMOVAL OF SQUEEGEE:



The machine is equipped with a squeegee at the rear of the machine. The squeegee is used to suck the dirty water from the floor after scrubbing. The squeegee has a unique feature “Break Away” which separates the squeegee from the machine upon an impact. This feature protects the squeegee from being damaged.

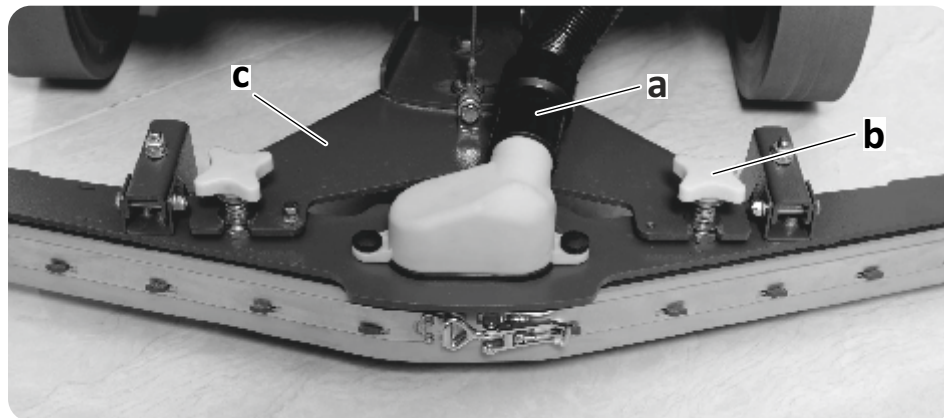

To dismount the squeegee:

- Ensure that the squeegee is in raised position.
- Detach the suction hose (a) from the squeegee's suction port.
- Loosen the yellow colored knobs (2 nos) (b).
- Remove the squeegee from the squeegee holder (c).

To mount the squeegee:

- Ensure that the squeegee is in raised position.
- Insert the squeegee into the squeegee holder (c).
- Tighten the yellow colored knobs (2 nos) (b).
- Attach the suction hose (a) into the squeegee's suction port.

MACHINE OPERATION

RAISING/LOWERING OF BRUSH HEAD:

For Standard Version:

To lower the brush head release the lever from the locking notch and lower it all the way downwards till the brush head rests on the floor.

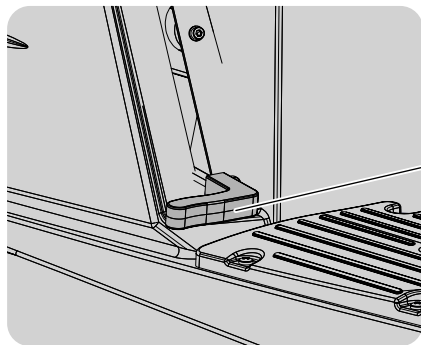

*Lever in lower position:
Brush head lowered.*

To raise the brush head pull the lever upwards and place it in the notch provided. The brush head is completely lifted. The brush motor stops when the brush head is raised.

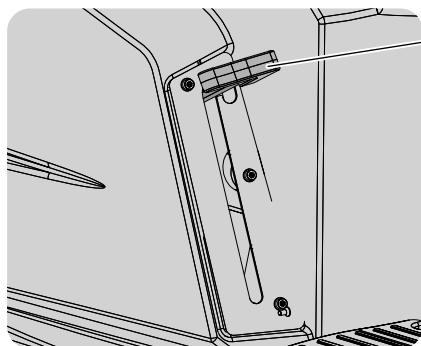

*Lever in raised position:
Brush head is raised and secured.*

Note: Brushes will not rotate until the accelerator pedal is pressed.

For Premium Version:

In the premium version the brush head is lowered via an electric actuator controlled by a switch on the control panel. Press the switch once to select the brush head. An LED will blink notifying the operator that the brush head is pre selected. The brush head will lower and the brushes will rotate when the accelerator pedal is pressed.



Press the switch once again to raise the brush head, upon which the brushes also stop rotating. The brush head will also raise automatically when the accelerator pedal is released. The brushes will also stop rotating.

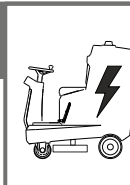

MACHINE OPERATION

RAISING/LOWERING OF SQUEEGEE:

For Standard Version:

To lower the squeegee release the lever from the locking notch and lower it all the way downwards till the squeegee rests on the floor.
The suction turbine will start running as soon as the squeegee is lowered.

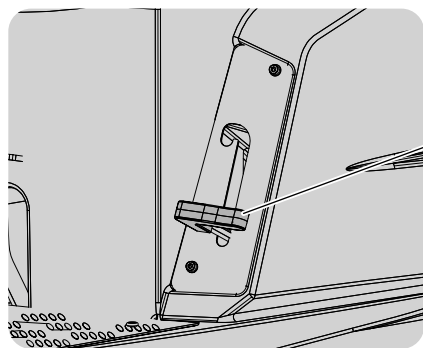

Lever in lower position:
Squeegee is lowered.

To raise the squeegee pull the lever upwards and place it in the notch provided. The squeegee is completely lifted.
The suction turbine will shut off after a delay of 15 seconds.

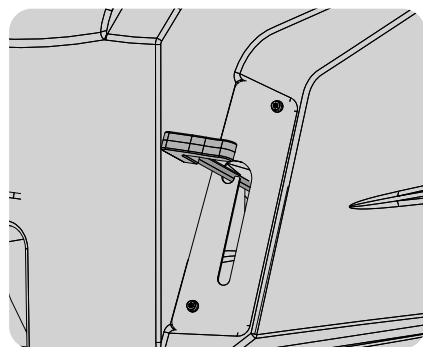

For Premium Version:

In the premium version the squeegee is lowered via an electric actuator controlled by a switch on the control panel. Press the switch once to select the squeegee. An LED will blink notifying the operator that the squeegee is pre selected. The squeegee will lower and the suction turbine starts when the accelerator pedal is pressed.



Press the switch once again to raise the squeegee, the squeegee will raise immediately.

The suction turbine will stop after a delay of 15 seconds.

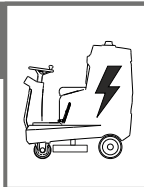

MACHINE OPERATION

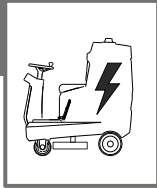

FLOAT SYSTEM:

The machine is equipped with two floats for suction turbine shut-off function.

1. Mechanical Float - The mechanical float is located inside the dirty water tank. It shuts off the vacuum immediately when the float block touches the top of the suction unit.

2. Electrical Float - The electrical float is located inside the dirty water tank. It switches off the machine as soon as the water level rises above the set value. This function is used to prevent any unwanted damage to the suction turbine.

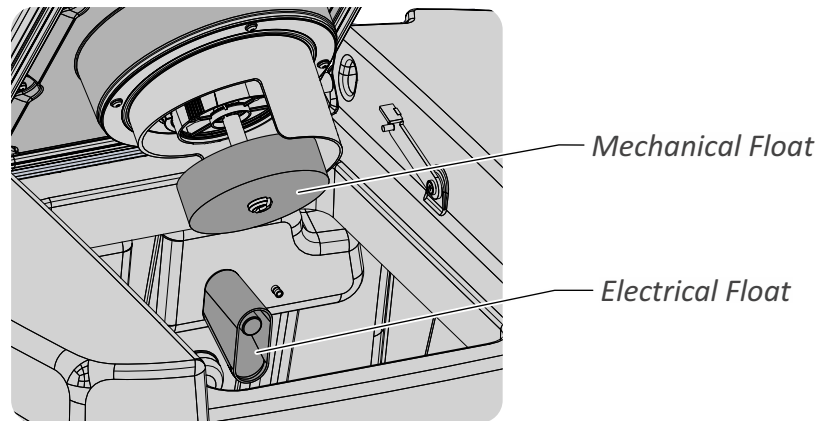

Standard Version

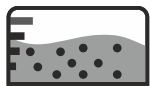

The dirty water tank full indicator LED on the control panel lights up when either of the float is activated.

Premium Version



The message “**TANK FULL**” will be displayed on the LCD panel.

BRUSH & PAD:

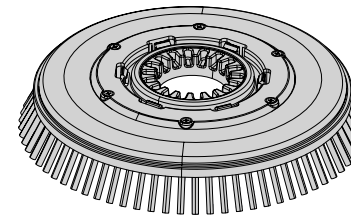

Disc Brush

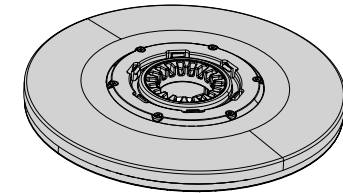

Pad Holder

For best results, use the appropriate brush or pad for the scrubbing application. Listed below are brushes and pads and the application for which each is best suited.

Polypropylene Brush - This brush is used for medium to high traffic areas. Used for floors with grout lines or uneven surfaces.

Nylon Brush - This brush is used for light duty scrubbing. Floor types: Marble, Terrazzo, Granite, Tiled Floors, Manmade Soft / Polished Floors.

Silicon Carbide Brush - This brush is used for heavy duty scrubbing and stripping. Also suitable for aggressive cleaning of hard floors. Floor types: Industrial Concrete Floors.

Pad Selection:

For best recommendations, contact your Roots Multiclean Ltd. executive for pad applications.

MACHINE OPERATION

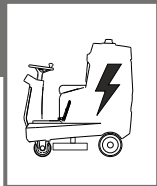

AUTO MODE SETTING:

Follow the below steps to use AUTO mode:

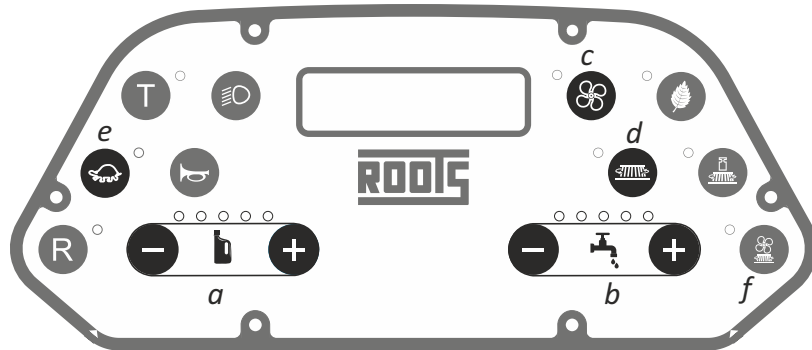

- Insert key into key switch.
- Switch On key switch.
- Press “a” & “b” switches to the required level.
- Press “c” & “d” to select suction turbine and brush motor.
- Press “e” to select speed.
- Upon pressing these switches the functions are pre-selected.
- Press and hold “f” switch for 3 seconds to save the *AUTO* mode values.
- Now the *AUTO* mode is ready to use.

MACHINE OPERATION

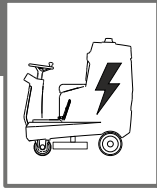

SCRUBBING PROCEDURE:

FOR STANDARD VERSION:

Before starting the machine ensure that the FNR switch is in neutral position, the emergency stop switch is released and the brush head/squeegee levers are in raised position.

Scrubbing:

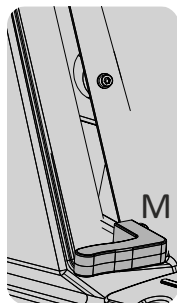
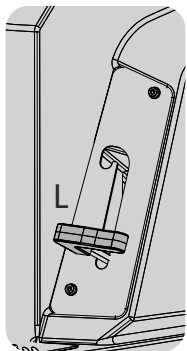
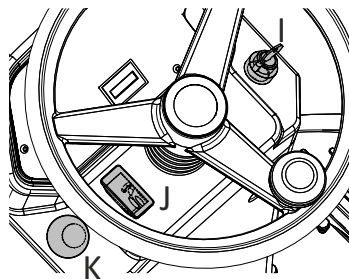
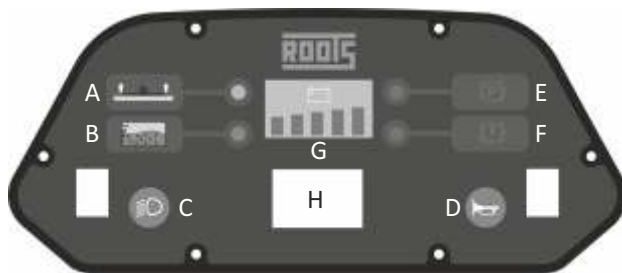

- A - Squeegee error
- B - Dirty water tank full
- C - Headlamp switch
- D - Horn switch
- E - Parking brake warning lamp
- F - Fault indicator lamp
- G - Battery charge indicator
- H - Hour meter
- I - Key switch
- J - Forward/reverse switch
- K - Emergency stop switch
- L - Squeegee raise/lower lever
- M - Brush head raise/lower lever

- Sit firmly in operator seat.
- Insert key into key switch (I). Ensure Emergency Stop Switch is released.
- Turn the key clockwise, the machine powers up. Beacon lamp is activated.
- Disengage the parking brake.
- Lower the brush head (M).
- Lower the squeegee (L).
- Select the required water flow level.
- Select forward direction of travel (J).
- Press the accelerator pedal to start scrubbing.
- Use the steering wheel to manoeuvre the machine.
- Use headlamp to operate the machine in dark or low lit areas (C).
- Use the horn to warn by-standers (D).
- Monitor the battery performance via the battery charge indicator in the control panel (G).
- The hour meter displays the total hours the machine is used for cleaning (H).
- To move the machine in reverse: Raise squeegee and brush head. Select reverse in FNR switch (J). Press accelerator. Note: The squeegee error indicator LED (A) glows if the machine is set in reverse without the squeegee being lifted.
- The fault indicator (F) lights up when there is any problem with the machine. If so stop operating the machine and call service.
- Use the emergency stop switch (K) during emergency only.
- The “Dirty Water Tank Full” LED (B) will glow when the dirty water tank is full. Drain the dirty water tank to continue scrubbing.

WARNING: Do not use the emergency stop switch to shut down the machine during regular operations.



WARNING: DO NOT drain the dirty water into the environment. Risk of contaminating the environment.

MACHINE OPERATION

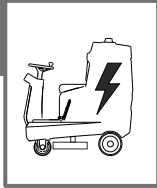

SCRUBBING PROCEDURE:

FOR STANDARD VERSION:

End of Scrubbing:

- Set water flow control lever to lower position (closed).
- Raise the brush head.
- Raise the squeegee, *vacuum motor shuts off after 15 seconds.*
- Move machine to parking area.
- Engage parking brake.
- Switch off key switch. Remove key.

MACHINE OPERATION

SCRUBBING PROCEDURE:

FOR PREMIUM VERSION:

Before starting the machine ensure that emergency stop switch is released.

Scrubbing:

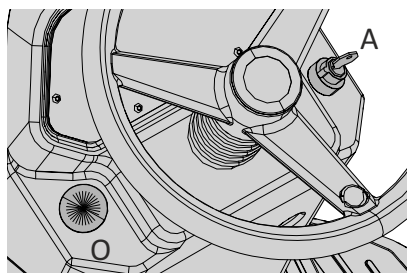

- A - Key switch
- B - Brush head switch
- C - Vacuum motor switch
- D - Fresh water switch
- E - Dosing switch
- F - Reverse mode switch
- G - Speed select switch
- H - Transport mode switch
- I - Head lamp switch
- J - Horn switch
- K - ECO mode switch
- L - Deep clean mode switch
- M - AUTO mode switch
- N - LCD panel
- O - Emergency stop switch

- Sit in operator seat.
- Insert key into key switch (A). Ensure that the Emergency Stop Switch is released.
- Turn the key clockwise, the machine powers up. Beacon lamp is activated.
- Press switch to pre-select the brush head (B).
- Press switch to pre-select the squeegee & vacuum motor (C).
- Select the required water flow level (D).
- Select the required chemical dosing level (E).
- Disengage the parking brake.
- Press the accelerator pedal to start scrubbing, machine moves in forward direction only.
- To travel in reverse direction select (F) in the control panel, upon which all scrubbing and vacuuming functions are disengaged and machines moves in reverse direction.
- To continue scrubbing press the (F) switch once again.
- Use the steering wheel to manoeuver the machine.
- Use headlamp to operate the machine in dark or low lit areas (I).
- Use the horn to warn by-standers (J).
- Monitor the battery performance via the LCD panel in the control panel (N).
- The hour meter displays the total hours the machine is used for cleaning (N).
- The fault indicator is displayed in the LCD panel when there is any problem with the machine.
- Use the emergency stop switch (O) during emergency only.
- Use "ECO" (K) & "AUTO" (M) mode whenever required.
- Use switch (L) for deep cleaning function.
- Use switch (G) for changing speed slow and fast.
- Use switch (H) to transport the machine during scrubbing operation.



WARNING: Do not use the emergency stop switch to shut down the machine during regular operations.

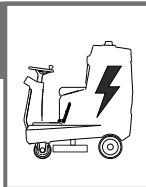

MACHINE OPERATION



SCRUBBING PROCEDURE:

End of Scrubbing:

- Switch off all scrubbing functions.
- Raise brush head and squeegee.
- Shut-off all water and dosing systems.
- Move machine to next cleaning area or park machine.
- Engage parking brake.
- Switch off key switch and remove key.
- Clean the float.
- Drain any remaining water from the fresh water tank if it is the end of the shift.
- Drain the dirty water tank only in the designated waste disposal area.
- Clean the dirty water tank with clean water.
- Remove squeegee and clean with fresh water.



WARNING: DO NOT drain the dirty water into the environment. Risk of contaminating the environment.

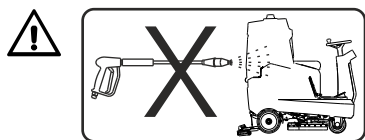

WARNING:

- **Do not clean the machine by means of a vapor jet or a high pressure cleaning equipment. Clean the brush head with a water hose (pressure: 5 to 6 bar max.) and from the bottom only.**
- **Do not direct the water jet into any opening, slots, on electronic modules, control panels or sealing.**
- **Do not use harsh chemicals to clean the machine.**
- **Wipe the machine with a damp cloth after usage.**

Post-Scrubbing Checkpoints

- *Check the tank lid seals for damage or wear and tear.*
- *Clean the float.*
- *Check the condition of the brushes. Remove any string, rope or other debris wrapped around them.*
- *Check the vacuum hose for block/damage.*
- *Check if both the tanks are completely clean.*
- *Check the machine exteriors for any damages or dirt.*
- *Check if the squeegee knobs are tight.*
- *Check the squeegee wheel for damage.*
- *Check the battery charge levels.*

MACHINE OPERATION

BATTERY CHARGING PROCEDURE (OFF-BOARD CHARGER)

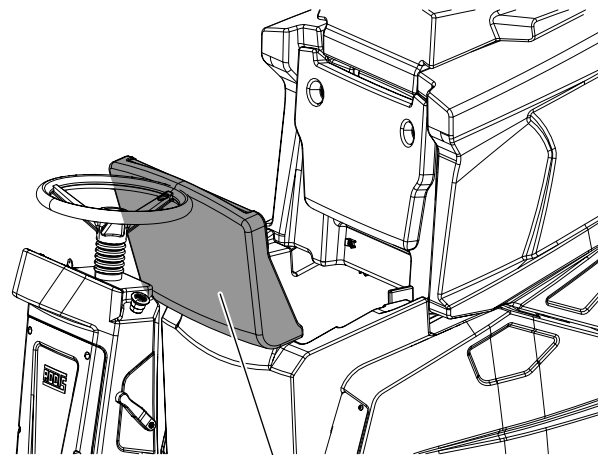
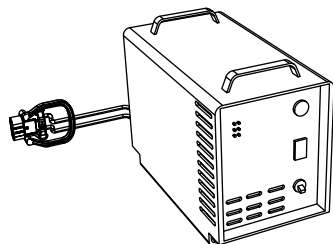
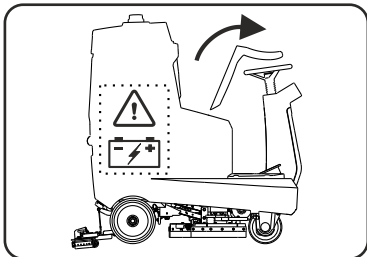

Operator Seat in Open Position

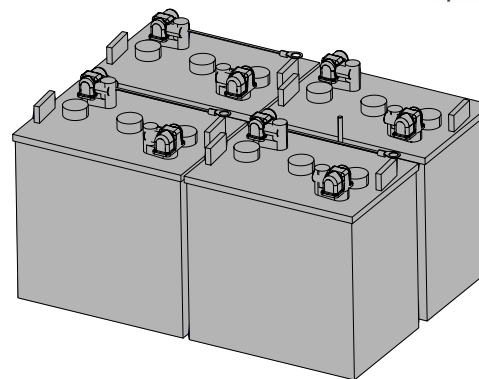

NOTE:

Before charging, make sure that the charger setting is properly set for the battery type.

Make sure the batteries have proper electrolyte level before charging.

- Drive the machine to a flat, dry surface in a well-ventilated area.
- Stop the machine and turn off the key switch. Remove key.
- Lift the operator seat.
- Disconnect the battery plug from the battery to the machine.
- Connect this to the charger outlet.
- Switch On the battery charger. When the batteries are fully charged, the charger will automatically turn off.
- After the charger has turned off, unplug the battery plug.
- Close the operator seat.



WARNING: Batteries emit hydrogen gas. Explosion or fire can result.
Keep sparks and open flames away. Keep covers open when charging.

NOTE:

If the charger “FAULT CODE” light flashes when the batteries are plugged into the charger, refer to the charger manufacturer manual for fault code definitions.

WARNING:

Do not disconnect the charger DC cord from the machine receptacle when the charger is operating. Arcing may result. If the charger must be interrupted during charging, disconnect the AC power supply cord first.

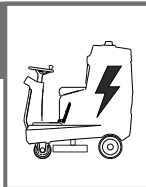

MACHINE OPERATION

To Swap / Replace Batteries:

The drained batteries can be swapped or replaced with charged batteries to continue scrubbing in an uninterrupted way.

- Park the machine on a flat level ground. Ensure that the surface is completely dry and clean.
- Turn off key switch and remove key.
- Engage parking brake.
- Open the operator seat.
- Tip the dirty water tank till the safety prop is engaged.
- Unplug the battery plug.
- Disconnect inter-battery connections.
- Remove the drained battery.
- Clean the battery tray with a dry cloth.
- Replace with charged batteries, reconnect inter-battery connection.
- Plug the battery plug.
- Disengage the safety prop by lifting the lever and lower the dirty water tank.
- Close operator seat. Machine is now ready for use.

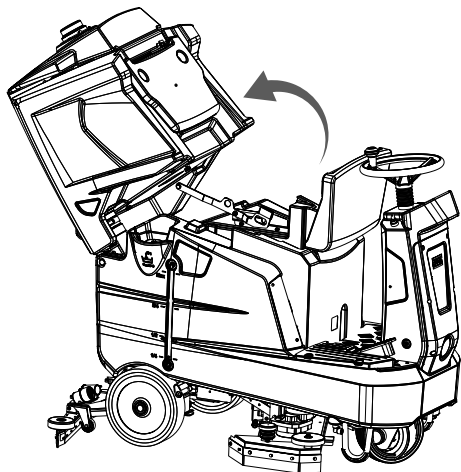

Safety Prop Engaged



WARNING: Care should be taken while lowering the dirty water tank to avoid hand being crushed.

Battery Connecting Diagram:

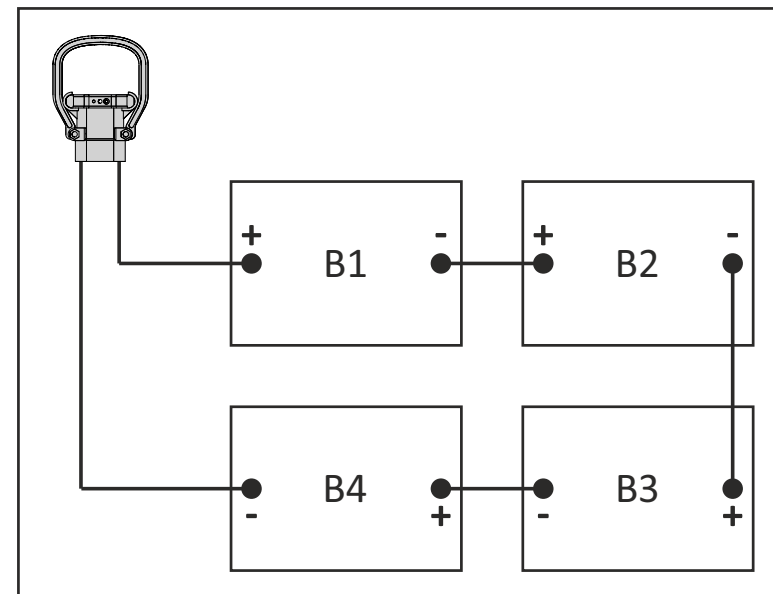



MAINTENANCE

MAINTENANCE

MAINTENANCE WORK

Compliance with our recommendations concerning maintenance work will give you the certitude always having a machine at your disposal, which is ready to work and in good operating condition.

Please contact your local Roots Multiclean Ltd. dealer. The people there will be glad to perform that work for you. Their well trained personnel and genuine Roots spare parts are at your disposal.

- Well trained personnel and genuine Roots spare parts are at your disposal.
- In case of any inquiry or order for spare parts, please always quote the machine's serial number mentioned on the nameplate.
- The name plate is fixed in the rear side of the machine.
- When cleaning or servicing the machine, and when replacing any part, shut off the machine and on principle disconnect the power plug from the power supply.
- For reasons of safety during cleaning and/or maintenance work in or on the tank, the tank lid - when lifted - must be secured so as to prevent accidental closing or tilting down.
- The machine may be taken into operation only if all guarding devices are fitted and in protective position. As far as possible, cleaning should not be done by hand, but using appropriate tools or equipment.
- Maintenance and repair work may be carried out only by means of suitable tools and by the people trained in the factory. For reasons of safety, only genuine Roots spare parts may be used.



WARNING

- **Maintenance and/or repair operations must be done by skilled and authorized personnel; all operations on electrical devices are to be performed by specialized personnel only.**
- **Read this manual thoroughly before performing any repair or maintenance operations.**
- **For repair and/or maintenance of high reach areas of the machine, use a suitable work lift or working platforms.**
- **Use genuine Roots spare parts ONLY which are specifically designed for the machine.**
- **USE suitable PPE at all times when working or servicing the machine.**

IMPORTANT!

- **ALWAYS SWITCH OFF AND REMOVE KEY BEFORE PERFORMING ANY MAINTENANCE OR REPAIR WORK.**
- **ALWAYS ATTACH A 'DO NOT START' OR SIMILAR WARNING SIGN TO THE KEY SWITCH OR A CONTROL BEFORE CLEANING OR SERVICING THE MACHINE.**



MAINTENANCE

MAINTENANCE

This section describes the maintenance of the machine under the following topics:

- DRAINING THE DIRTY WATER TANK.
- DRAINING THE FRESH WATER TANK.
- CLEANING THE DIRTY WATER TANK.
- CLEANING THE FLOAT.
- CLEANING THE FRESH WATER TANK.
- CLEANING THE SQUEEGEE.
- CLEANING THE SQUEEGEE LIPS.
- CLEANING THE DISC BRUSHES.
- CLEANING THE CATCH HOLDER.
- CLEANING THE FRESH WATER FILL PORT STRAINER.
- CLEANING THE FRESH WATER FILTER (PUMP IN-FEED).
- CLEANING THE MACHINE.
- GREASING THE CHAIN DRIVE.
- SKIRTS & SEALS.
- TYRES.
- PUSHING & TRANSPORTING THE MACHINE.
- ELECTRICAL MAINTENANCE.
- BATTERIES.
- STORING THE MACHINE.
- FREEZE PROTECTION.
- MAINTENANCE SCHEDULE CHART.

DRAINING THE DIRTY WATER TANK



- Move the machine to the designated waste disposal area.
- Lower the dirty water tank drain hose to the floor.
- Open the cap of the drain hose.
- Upon end of draining close the cap and secure the hose in its storage position.

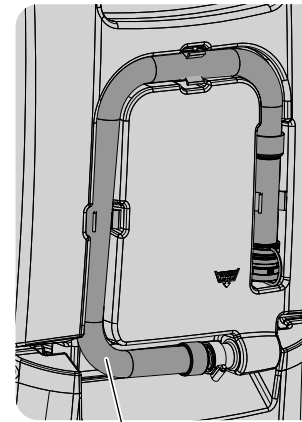

Drain Hose

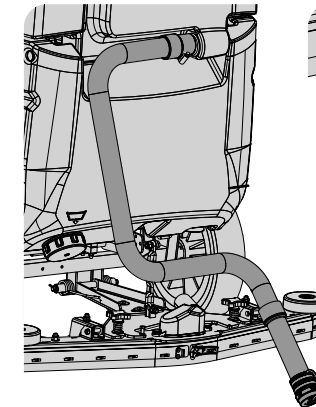

Lower Drain Hose

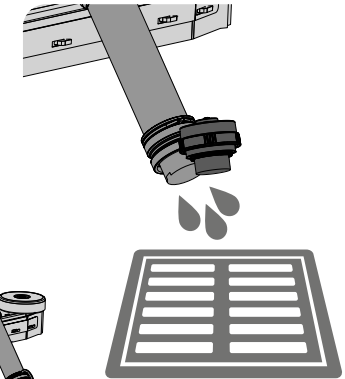

Unscrew cap to drain

WARNING



DO NOT DRAIN THE DIRTY WATER INTO THE ENVIRONMENT. RISK OF CONTAMINATING THE ENVIRONMENT.



MAINTENANCE



DRAINING THE FRESH WATER TANK



- Move the machine to the designated waste disposal area.
- Open the cap of the fresh water tank, drain the remaining water.
- Clean the tank with fresh water.
- Close the cap.

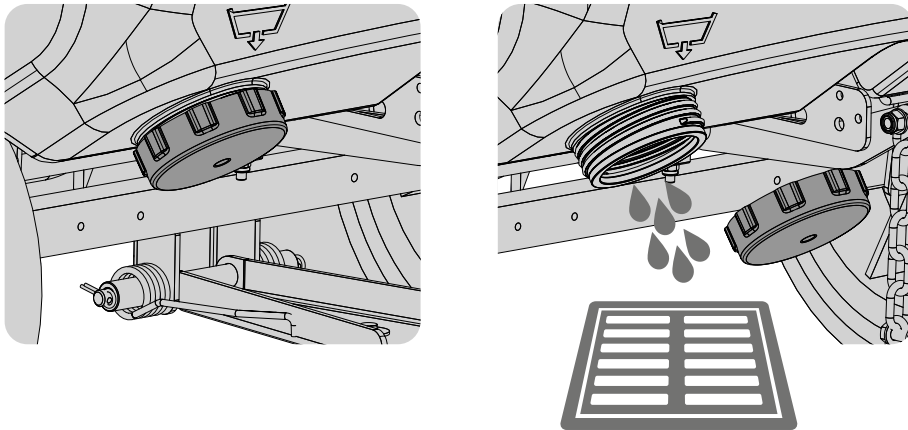

Unscrew cap to drain

WARNING



DO NOT DRAIN THE FRESH WATER INTO THE ENVIRONMENT. RISK OF CONTAMINATING THE ENVIRONMENT.

CLEANING THE DIRTY WATER TANK



- Move the machine to the designated cleaning area.
- Open the lid of the dirty water tank.
- Secure the lid by engaging the stopper.
- Lower the dirty water tank drain hose near the drain, open the cap of the drain hose.
- Use fresh water at normal pressure and clean the inside of the dirty water tank completely. Use mild detergent if required.
- Clean the dirty water tank until it is free from any debris or foreign matter.
- Keep the lid open for a few minutes for the tank to dry.

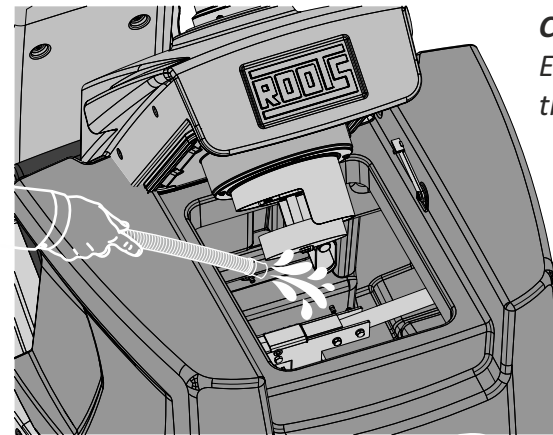

Caution:

Ensure that water does not enter the suction turbine.

WARNING



DO NOT DRAIN THE DIRTY WATER INTO THE ENVIRONMENT. RISK OF CONTAMINATING THE ENVIRONMENT.

MAINTENANCE



CLEANING THE FLOAT



- Move the machine to the designated cleaning area.
- Open the lid of the dirty water tank, secure it with the stopper.
- Lower the dirty water drain hose near the drain, open the cap of the dirty water tank drain hose.
- Remove the float from the yellow color float holder.
- Clean the float with clean running water.
- Twist to unlock and remove the float holder. Remove any debris from the float holder, clean the float holder with clean water. Use mild detergent if required. Use a brush to remove any salt or dirt deposit on the mesh of the float holder.
- Drain all water from the dirty water tank.
- Clean the dirty water tank.
- Close the dirty water tank drain hose cap and secure it in its holder.
- Disengage the safety stopper and close the lid.

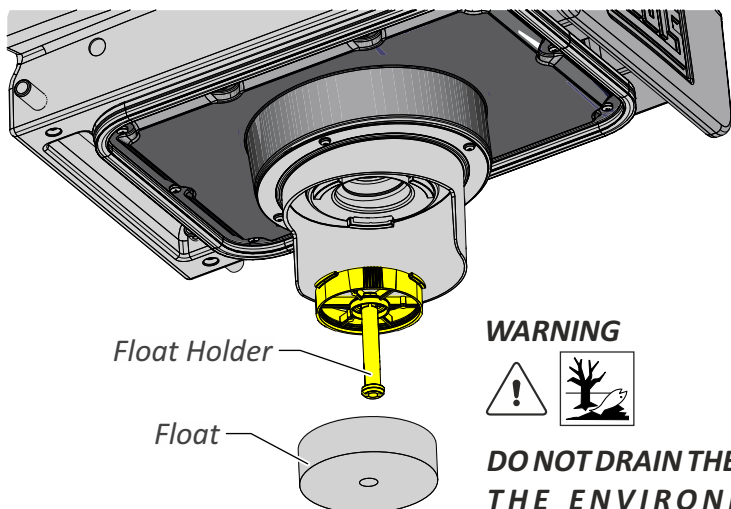

WARNING



DO NOT DRAIN THE DIRTY WATER INTO THE ENVIRONMENT. RISK OF CONTAMINATING THE ENVIRONMENT.

CLEANING THE FRESH WATER TANK



- Move the machine to the designated cleaning area.
- Open the cap of the fresh water tank.
- Drain any remaining water.
- Open the fresh water fill port cap.
- Use fresh water at normal pressure and clean the inside of the fresh water tank completely. Use mild detergent if required.
- Drain all water.

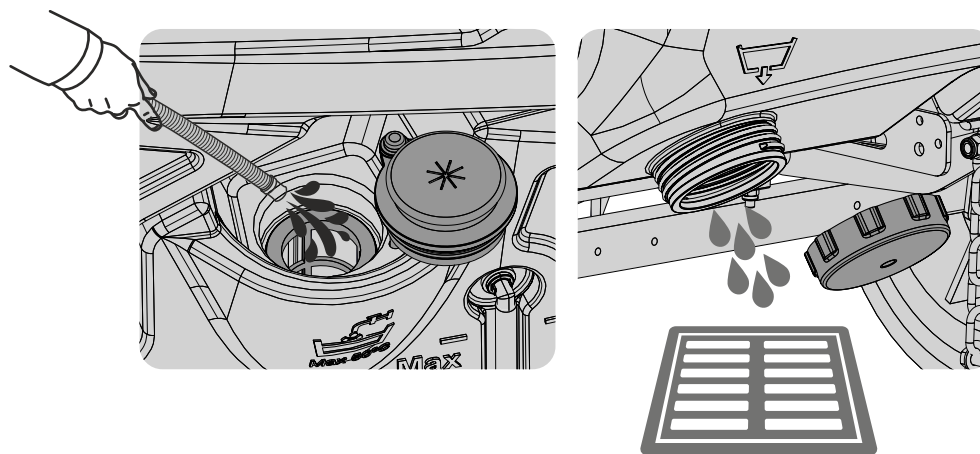

WARNING



DO NOT DRAIN THE DIRTY WATER INTO THE ENVIRONMENT. RISK OF CONTAMINATING THE ENVIRONMENT.

MAINTENANCE

CLEANING THE SQUEEGEE



- Move the machine to the designated cleaning area.
- Remove the squeegee from the machine by loosening the yellow colored squeegee holder knobs (2 nos.).
- Detach the suction hose from the squeegee.
- Remove any debris, thread, rope etc from the squeegee.
- Clean the squeegee under running water.
- Remove the squeegee suction port by removing the suction port holder knobs (2 nos.).
- Remove any debris, thread, rope etc from the suction port.
- Clean the suction port under running water. Use mild detergent if required.

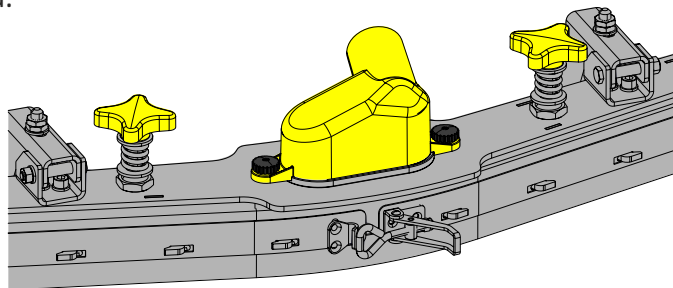

The suction port and retaining knobs are in a bright yellow color for easy identification of maintenance components which have to be removed and cleaned.

WARNING



DO NOT CLEAN THE SQUEEGEE AND ITS COMPONENTS INTO THE ENVIRONMENT. RISK OF CONTAMINATING THE ENVIRONMENT.

WARNING



DO NOT USE HARSH CHEMICALS AND ACIDS TO CLEAN.

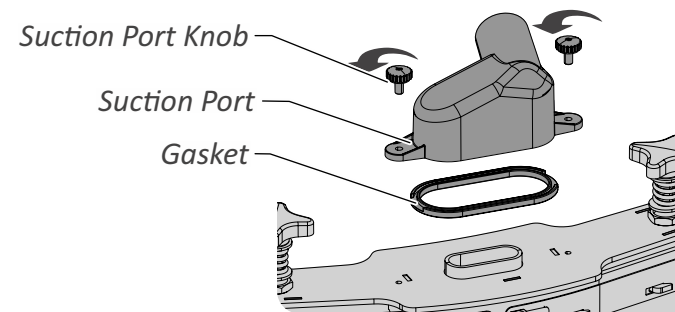

After removal of the suction port, clean the retaining gasket under clean running water. Do not use harsh acids or chemicals.



NOTE: ENSURE THAT THE SUCTION PORT GASKET IS PLACED PROPERLY TO PREVENT VACUUM LEAK.



MAINTENANCE



CLEANING THE SQUEEGEE LIPS



- Remove the squeegee lip holder using the toggle clamp. Pull the toggle latch forward to loosen the clamp.
- Remove both front and back squeegee lip holders.
- Remove any debris, thread, etc.
- Remove the squeegee lips and clean them under clean running water. Use mild detergent.
- Assemble the lips back after cleaning.
- Secure the lips using the squeegee lip holder via the toggle clamp.

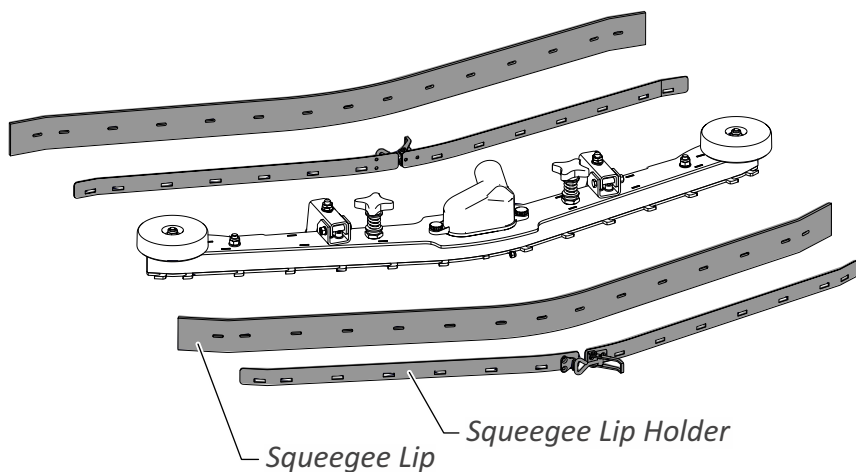

WARNING



DO NOT USE HARSH CHEMICALS AND ACIDS TO CLEAN.

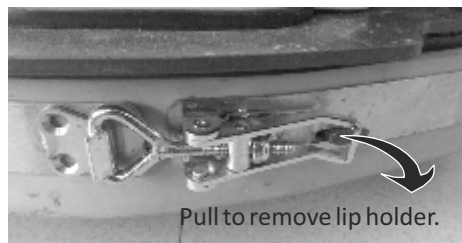

CLEANING THE DISC BRUSHES



- Remove the disc brushes from the brush head by pressing the brush release pedal.
- Remove any thread, rope, twine and other debris from the brushes.
- Clean the brushes under clean running water.
- Clean the catch holder grooves using a small brush.

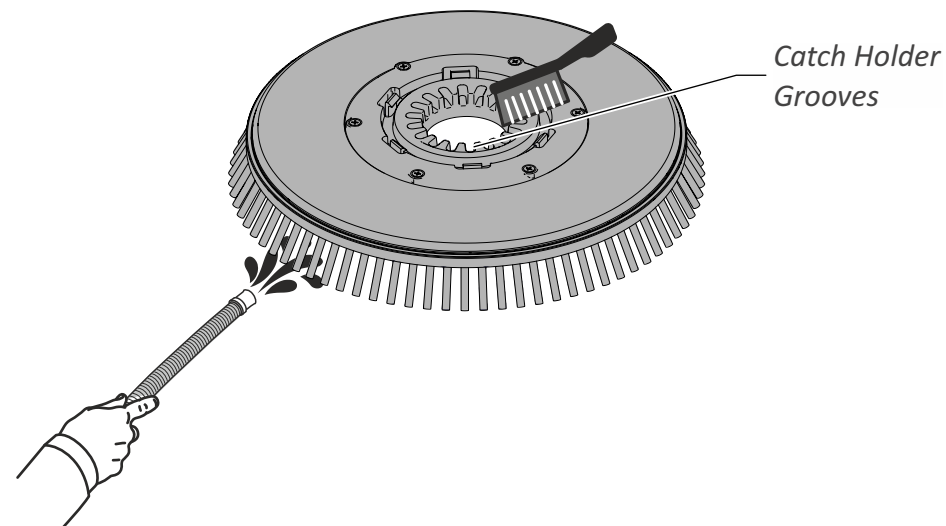

WARNING



DO NOT USE HARSH CHEMICALS AND ACIDS TO CLEAN.

MAINTENANCE



CLEANING THE CATCH HOLDER



- Clean the catch holders using a water hose at normal pressure.
- Remove any thread, rope, twine and other debris from the catch holders.
- Use a small brush to remove the dust particles.

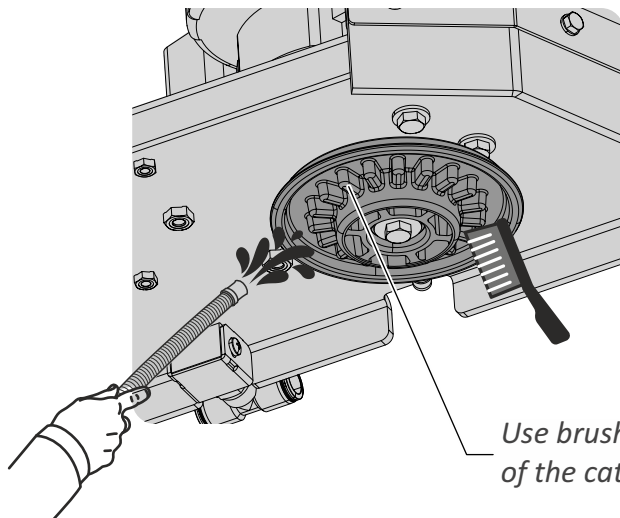

Use brush to clean this area of the catch holder.

CLEANING THE FRESH WATER FILL PORT STRAINER



- Open the fresh water fill port rubber cap.
- Remove the strainer by pulling it upwards.
- Remove any debris from the strainer.
- Clean the strainer under clean running water. Use a brush to clean any salt deposits. Use mild detergent if required.

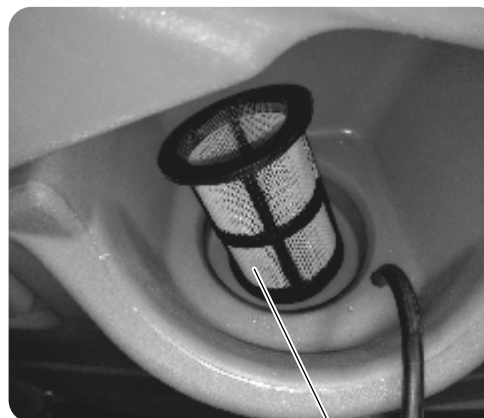

Fill Port Strainer

MAINTENANCE

CLEANING THE FRESH WATER FILTER



- Unscrew the body of the filter assembly (a).
- Remove the strainer from the assembly (b).
- Remove any debris from the strainer.
- Clean the strainer under clean running water. Use mild detergent if required. A brush can be used to remove any salt deposit.
- Clean the O-Ring (c). Use clean water only. Ensure that the O-Ring is placed in the proper position before tightening the assembly. If failed to do so, there is a risk of water leak.

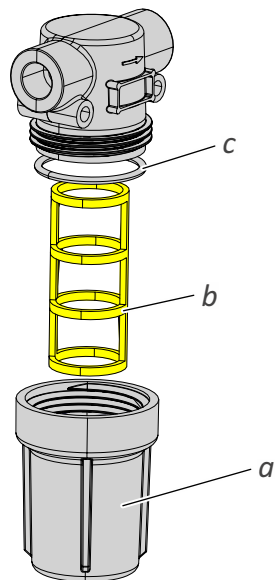

WARNING

Do not over tighten, risk of breakage, risk of leak and component damage.



CLEANING THE MACHINE



- Use a damp sponge with mild detergent to clean the exteriors of the machine.
- Ensure that water does not enter any electrical part.
- **DO NOT** use a high pressure jet or steam cleaning equipments to clean the machine.

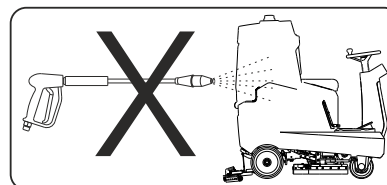
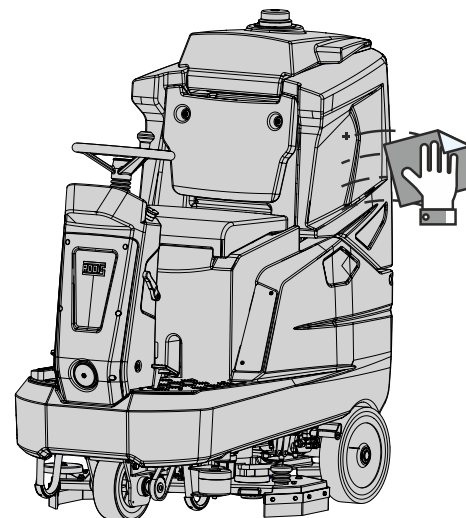

DO NOT CLEAN THE MACHINE BY MEANS OF VAPOUR JET OR HIGH PRESSURE CLEANING EQUIPMENT.

MAINTENANCE



GREASING THE CHAIN DRIVE



- The machine uses a chain drive to transmit power to the drive wheel at the front. This chain has to be kept clean and to be lubricated at specified maintenance intervals.
- Use recommended grease only. Apply with brush or grease gun.

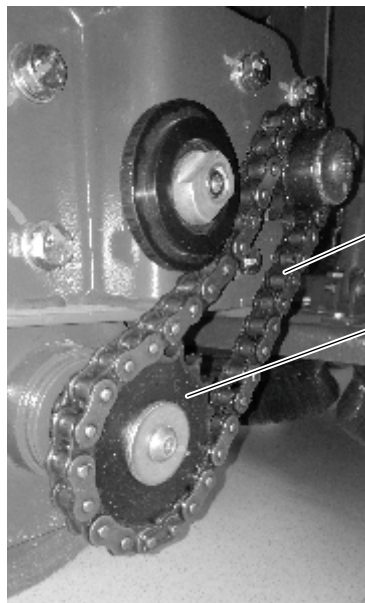

Note: Apply grease on outer surface of chain and sprocket only.

Chain

Sprocket

Recommended Grease: OKS 410 HIGH PERFORMANCE
Duration is every 200 Hrs.

SKIRTS AND SEALS

NOTE: Before leaving or servicing the machine, stop on a level surface, turn off key switch, engage the parking brake and remove key.

Dirty Water Tank Seal



Check the dirty water tank lid seal for damage and wear daily.

Brush Head Side Skirts

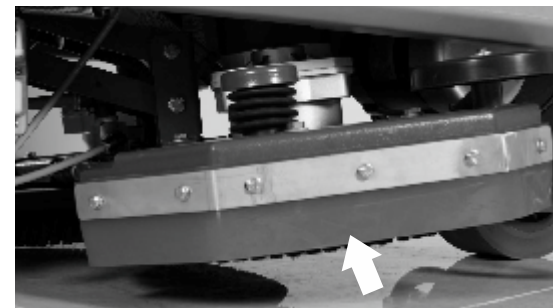

Check the brush head side skirts for damage and wear after every 50 hours of operation.

MAINTENANCE



CHANGING THE SQUEEGEE LIPS



- Remove the squeegee lip holder using the toggle clamp. Pull the toggle latch forward to loosen the clamp.
- Remove both front and back squeegee lip holders.
- Remove the front and rear squeegee lips.
- If the squeegee lips are in good condition invert them to use the other side.
- If the squeegee lips are completely worn out, replace the same with new ones.
- Secure the lips using the squeegee lip holder via the toggle clamp.

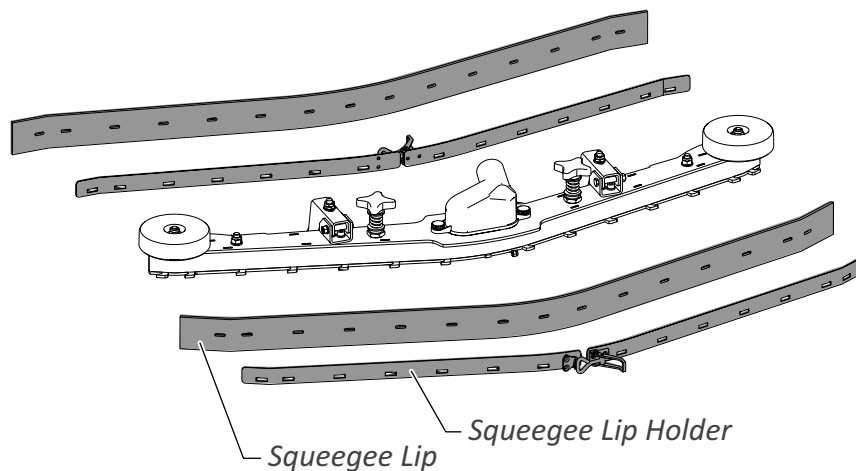

Note: While reassembling the squeegee lip holders ensure they are not inverted. risk of damaging the floor.



TYRES

NOTE: Before leaving or servicing the machine, stop on a level surface, turn off key switch, engage the parking brake and remove key.

The machine has three solid rubber tyres: one in front, and two in the rear of the machine. Check the tyres for damage and wear.



— *Front Tyre*

— *Rear Tyre*

MAINTENANCE



PUSHING AND TRANSPORTING THE MACHINE

Pushing the Machine

(For Premium Version)

If the machine becomes disabled due to an error on the A1 & A2 control boards, the machine can be transported by activating the “*Crippled Machine Transport*” mode.

The parking brake must be disengaged before activating the disabled transport mode. An electric switch is located at the right hand bottom of the floor board under the machine. It is a three position switch, set the switch to forward mode. Press the accelerator pedal to move the machine.

In this mode only the drive motor will function, all other systems will be deactivated.

Important: After servicing the machine ensure that the “*Crippled Machine Transport*” switch is switched to Neutral, only then the machine can be used for scrubbing operations, if failed to do a error message will flash on the LCD panel to alert the operator.

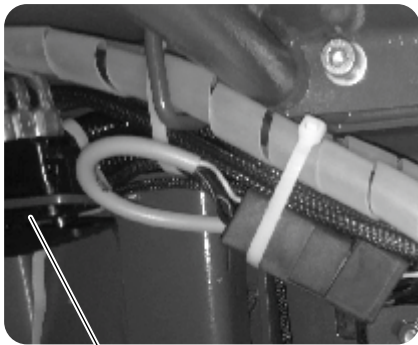

Switch - Crippled Machine Transport

Pushing the Machine

(For Standard Version)

If the machine becomes disabled, it can be pushed from the front or rear.

The parking brake must be disengaged before pushing the machine, now the machine can move freely. Push the machine slowly for a **very short distance** only. The drive system is NOT intended to be pushed for a long distance or at a high speed.



WARNING:

- × **DO NOT push the machine for a long distance, damage may occur to the drive system.**
- × **DO NOT tow the machine.**

Transporting the Machine

If the machine has to be transported to a different location ensure that the machine is secured properly. Follow the below steps for transporting.

- Raise the squeegee and brush head.
- Remove the squeegee and brushes from the machine.
- Drain fresh water tank and dirty water tank.
- Drain the solution tank if equipped.
- Place the pallet on a flat dry ground.
- Place the ramps in position.
- Drive the machine on to the pallet.
- Switch off key switch and remove key.
- Engage the parking brake.
- Position the front wheel in a perpendicular manner.
- Secure the front and rear wheel with blocks.
- Disconnect the battery plug.
- For added safety connect the tie-down straps to the left and right stabilizer bars in the front of the machine.

MAINTENANCE



ELECTRICAL MAINTENANCE

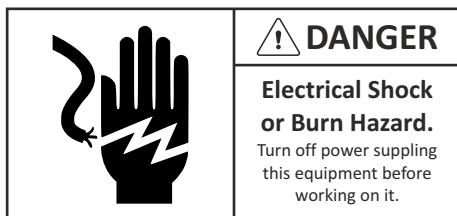

NOTE: Before leaving or servicing the machine, stop on a level surface, turn off key switch, engage the parking brake and remove key.

IMPORTANT: All electronic or electrical repairs should be done by authorized Roots Multiclean Ltd. service engineer **ONLY**.

The machine control board (electrical module) is located at the front of the machine, in the steering pillar assembly. To access the electronic components remove the front cover.

The man-machine interface control board is located at the top of the steering column assembly.



Machine Control Board



Man-Machine Interface

Note: Pictures shown are for premium version.

Fuse:

A variety of fuses are used to protect the electrical systems in case of a failure. In an event of a blown fuse, a blue LED glows near the appropriate fuse.

To change the fuse:

- Switch off key switch, remove key.
- Open the front panel cover by removing the screws.
- Pull out the blown fuse from the socket.
- Insert a new fuse of the same rating into the fuse holder.
- Switch on key switch.
- Activate the corresponding system to check its function.

IMPORTANT:

If there should be repeated cases of failure, look for reason.



ELECTRICAL MAINTENANCE

List of Fuses

FUSE DETAILS - STANDARD VERSION

FUSE	RATING	USED FOR
F1	35A	Brush Motor 1
F2	35A	Brush Motor 2
F3	35A	Vacuum Motor
F4	2A	Solenoid Valve
F5	2A	Beacon Lamp
F6	2A	Drive
F7	2A	Buzzer
F8	5A	Horn, Light
F9	2A	Circuit
F11	70A	Main Contactor Fuse
F12	70A	Drive Controller Fuse

FUSE DETAILS - PREMIUM VERSION

FUSE	RATING	USED FOR
F2	100A	Main Fuse
F3	40A	Brush Motor 1
F4	40A	Actuator
F4	40A	Pump
F4	40A	Light
F4	40A	Horn
F5	40A	Brush Motor 2
F6	40A	Vacuum Motor



Error Codes:

In the event of an error in the machine, the diagnostic system displays a error code in the LCD panel, upon which the fault can be rectified
(For premium version only).

ERROR CODE	ERROR DESCRIPTION	REMEDY
E01	Fuse Blown	Fuses in A2 board rated at 40 amps might blow over a period of time due to use. An LED glows in RED to highlight the point of failure. Replace fuse of the same type. If the fuses fail again, contact RMCL Service/Dealer immediately.
E03	A2 TOP Error	Brush motor tripped due to overheat, wait for 15 minutes approx. & then restart.
E04	No CAN comm check wiring No A1 CAN comm check wiring No A2 CAN comm check wiring	Check for loose electrical connection in CAN cables , correct the same and try restarting, if the problem presistes, contact RMCL Service/Dealer immediately.
E09	POT not functioning	POT setting to be recalibrated. Refer settings on maint section.
E10	Release Accelerator Pedal	While Key Switch is made ON , don't press accelerator pedal.
E11	Key input open in A3	Check wiring.
E12	Drive Motor Over Load	Ensure parking brakes are disengaged, remove foot from brake pedal, operate on normal floor.
E13	Over Voltage	Check Battery Voltage Rating, Turn Off key.
E14	Brake/Seat Switch Open	Check Switches/Wire loops are properly connected. Absence of operator. Disengage parking brake.
E15	Emergency drive SW-out of neutral	Set switch to neutral position.
E16	Charge the battery !	Complete machine shutdown. Recharge battery immediately.
25	SD Card Unavailable	Insert SD Card.
E20	SD Card fail	Format or replace with new SD Card.
E21	8701 Fault	Driver IC failed.
E22	BM overload	Turn off key.

MAINTENANCE

BATTERIES

The machine is equipped with lead acid (LA) type of batteries which require routine maintenance. Check the battery electrolyte level weekly.

NOTE: Before leaving or servicing the machine, stop on a level surface, turn off key switch, engage the parking brake and remove key.

The life of the batteries depends on their proper maintenance. To get the most life from the batteries;

- ☞ Do not charge the batteries more than once a day and only after running the machine for a minimum of 30 minutes.
- ☞ Do not leave the batteries partially discharged for a long period of time.
- ☞ Charge the batteries in a well-ventilated area only to prevent gas build up. Charge the batteries in areas with an ambient temperature of 27° C or less.
- ☞ Allow the charger to complete charging the batteries before re-using.
- ☞ Maintain proper electrolyte levels of flooded (wet) batteries by checking levels weekly.

CHECKING ELECTROLYTE LEVEL

(For Lead Acid Battery)



Checking the electrolyte level

The flooded (wet) lead-acid batteries require routine maintenance as described below. Check the battery electrolyte level weekly.

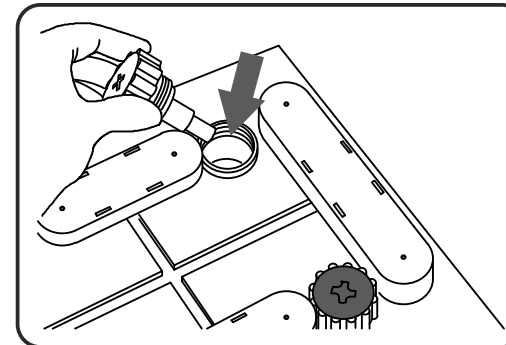

MAINTENANCE

CHECKING ELECTROLYTE LEVEL

(For Lead Acid Battery)

The level should be slightly above the battery plates as shown in the figure. Add distilled water if level is low. **DO NOT OVERFILL.** The electrolyte will expand and may overflow when charging. After charging, distilled water can be added up to about 3 mm below the sight tubes.

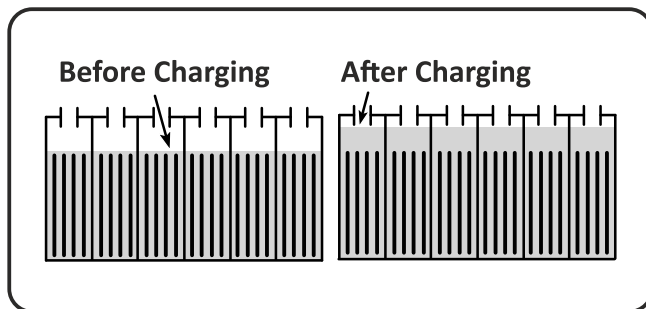

NOTE: Make sure that the battery caps are kept open while charging. There may be sulfur smell after charging batteries. This is normal.

MAINTENANCE-FREE BATTERIES

Maintenance-free batteries do not require watering. Cleaning is still required.

CHECKING CONNECTIONS / CLEANING

After every 200 hours of use check for loose battery connections and clean the surface of the batteries, including terminals and cable clamps, with a strong solution of baking soda and water. Replace any worn or damaged wire. Do not remove the battery cap when cleaning batteries.

Operator Safety Tips:

- ✓ Wash hands with soap after performing cleaning tasks on the batteries.



MAINTENANCE



STORING THE MACHINE

The following steps should be taken when storing the machine for an extended period of time.

- Charge the batteries before storing machine to prolong the life of the batteries. Recharge batteries once a month.
- Disconnect batteries before storing.
- Thoroughly drain fresh water tank, dirty water tank and all hoses.
- Store the machine in a dry area with the squeegee and brush head in raised position.
- Open the lid of the dirty water tank to promote air circulation.
- If storing the machine in freezing temperatures refer “FREEZE PROTECTION” section.

NOTE: Do not expose the machine to rain, store indoors only.



NOTE: To prevent potential damage to the machine store the machine in a insect and rodent free environment.



FREEZE PROTECTION

(For Premium Version)

NOTE: Before leaving or servicing the machine, stop on a level surface, turn off key switch, engage the parking brake and remove key.

- Completely drain the dosing tank and dirty water tank.
- Pour 3.0 Lts of Propylene Glycol Based / Automotive Grade antifreeze into the dosing tank.

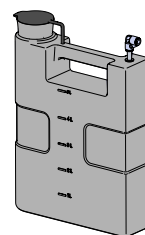

Dosing Tank

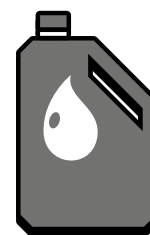

Antifreeze

- Start the machine.
- Set the dosing system to its maximum setting.
- Set the water system to its maximum setting.

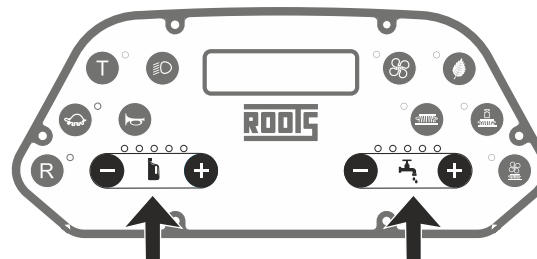

- Drive the machine to circulate the anti-freeze.
- Add clean water in the fresh water tank.
- Drive the machine to circulate clean water through the system to clear out the anti-freeze.
- Stop the machine.
- Turn off key switch and remove key.
- The remaining solution need not be drained from the dosing tank.

MAINTENANCE



MAINTENANCE CHART

The below table indicates the Person Responsible for each procedure:

O = Operator

T = Trained Personnel

Interval	Person Resp.	Description	Procedure
Daily	O	Batteries	Recharge batteries
	O	Dirty water tank	Empty and clean dirty water tank
	O	Squeegee	Check squeegee for foreign particles taken and clean if required
	O	Fresh water tank	Clean filter in fresh water fill port
	O	Fresh water tank	Clean mesh filter in water feed system
	O	Dirty water tank, Squeegee	Check tight fitting and condition of suction hose between squeegee and dirty water tank
	O	Suction turbine	Check suction turbine inlet filter and float assembly
	O	Flow diverter	Clean the flow diverter daiy to prevent debris accumulation
	O	Fresh water tank	Check fresh water supply to the brushes
50 Hours	T	Batteries	Check battery electrolyte levels
	T	Squeegee	Check squeegee lips deflection
	O	Squeegee	Check squeegee lips for wear and turn or replace if required
	O	Brushes	Check brushes for wear limit, replace if required

MAINTENANCE



MAINTENANCE CHART

Interval	Person Resp.	Description	Procedure
200 Hours	T	Batteries	Check battery poles and apply petroleum jelly if required
	T	Brake	Check function of brake
	T	Steering	Grease steering pinion and gear ring
	T	Drive train	Grease drive chain
	T	Pivot points	Check pivot and sliding points, apply grease as required
	O	Skirts	Check brush head side skirts for damage and wear
	T	Squeegee	Check squeegee holder and castor roller, re-adjust if required
500 Hours	T	Tyres	Check front and rear tyres for damage and wear
1000 Hours	T	Brush motor	Main brush motor: Check carbon brushes *
	T	Drive motor	Drive motor: Check carbon brushes *
	T	Suction turbine	Suction turbine: Check carbon brushes *

* - Check every 100 hours after initial 1000 hour check.



TROUBLESHOOTING



TROUBLESHOOTING

PROBLEM	CAUSE	REMEDY
No power - nothing works	Faulty power switch	Contact Roots service
	Battery needs to be recharged	Recharge battery
	Faulty battery	Replace battery
	Loose battery cable	Tighten loose cable
	Main fuse blown	Rectify the cause & Replace the fuse
Brush motor does not work	Accelerator pedal is not depressed	Press accelerator pedal
	Main fuse blown	Rectify the cause & Replace the fuse
	Faulty brush motor or loose cable	Contact Roots service
Suction turbine does not work	Faulty suction turbine switch	Replace switch
	Suction turbine fuse blown	Replace the fuse
	Faulty suction turbine	Contact Roots service
	Carbon brushes worn	Contact Roots service
Insufficient water flow	Water level in tank low	Refill fresh water
	Flow setting level at stop	Set flow level to On
	Water line clogged	Remove and blow with compressed air
	Water valve clogged	Remove and clean
	Pump not working	Check fuse/pump or replace fuse/pump
Poor water recovery	Dirty water tank is full	Empty dirty water tank
	Suction hose is clogged	Remove debris
	Squeegee is clogged	Remove debris
	Squeegee lip is worn	Rotate or replace lips
	Faulty vacuum hose	Contact Roots service
	Flow diverter is clogged	Clean flow diverter

TROUBLESHOOTING



TROUBLESHOOTING

PROBLEM	CAUSE	REMEDY
<i>Poor water recovery</i>	Tank gasket faulty	Contact Roots service
	Drain hose leak	Hook up drain hose and close
	Suction turbine faulty	Contact Roots service
	Battery charge low	Recharge battery
<i>Tires noisy</i>	Bearing dry	Grease bearings
	Faulty hubs	Contact Roots service
<i>Poor traction</i>	Excessive brush pressure	Reduce pressure
	Worn traction tire	Replace tyre
	Heavy soap concentration	Clean tyres
<i>Short run time</i>	Battery run down	Charge battery twice
	Battery still down	Contact Roots service
	Battery low on water	Refill with distilled water
	Battery over cycled	Contact Roots service



DO'S & DON'TS



DO'S

- ✓ Charge the batteries after it has been completely discharged.
- ✓ Charge the batteries only in a well ventilated area.
- ✓ Use only clean water to fill the fresh tank.
- ✓ Fill fresh water till the marked level only.
- ✓ Clean the fresh water filter after each cleaning cycle.
- ✓ Empty the dirty water at a specified draining area.
- ✓ Clean the dirty water tank and collection tray after each cleaning cycle.
- ✓ Clean the suction float assembly if any dirt is noticed.
- ✓ Clean the squeegee after every cleaning cycle.
- ✓ Use only recommend cleaning solutions.
- ✓ Wipe the machine at the end of the day.
- ✓ Drive at a slow speed on ramps and uneven surfaces.
- ✓ Use only recommended brushes for the specified floors.
- ✓ Park the machine in a covered dry place.

DON'TS

- × Do not charge the batteries between cleaning cycle.
- × Do not use the machine for transporting goods or persons.
- × Do not modify the machine.
- × Do not fill water beyond 50°C.
- × Do not use harsh or acidic solutions.
- × Do not empty the dirty water in a habitable area.
- × Do not drive with the fresh water tank open.
- × Do not stand on the brush head and squeegee.
- × Do not park the machine on ramps or slopes.
- × Do not place any objects on the battery while charging.
- × **DO NOT TAMPER WITH THE ELECTRICAL CIRCUITS.**
- × Do not open the electrical module cover.
- × Do not adjust the drive motor controller.
- × Do not clean the machine with a high pressure cleaning system.
- × Do not abuse the machine beyond its operable limit.
- × Do not mix brushes and use.
- × Do not park the machine by exposing it to the natural elements.
- × Do not use the machine to tow or push other equipments.
- × Do not over fill the distilled water in the battery.

OPERATOR NOTES



A large rectangular area with horizontal dotted lines, intended for handwritten operator notes.

OPERATOR NOTES



A large rectangular area with a black border, containing 25 horizontal dotted lines for writing operator notes.

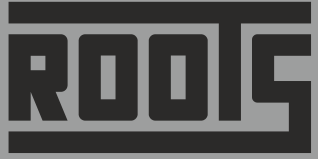

Roots Multiclean Ltd.

R.K.G. Industrial Estate, Ganapathy, Coimbatore - 641 006, India.

Phone: +91 (422) 4330 330, *E-mail:* rmclsales@rootsemail.com

Web: rootsmulticlean.com

Toll Free: **1800 41 99 77 9**