

RootsSweep RB100

Ride On Sweeper
Battery

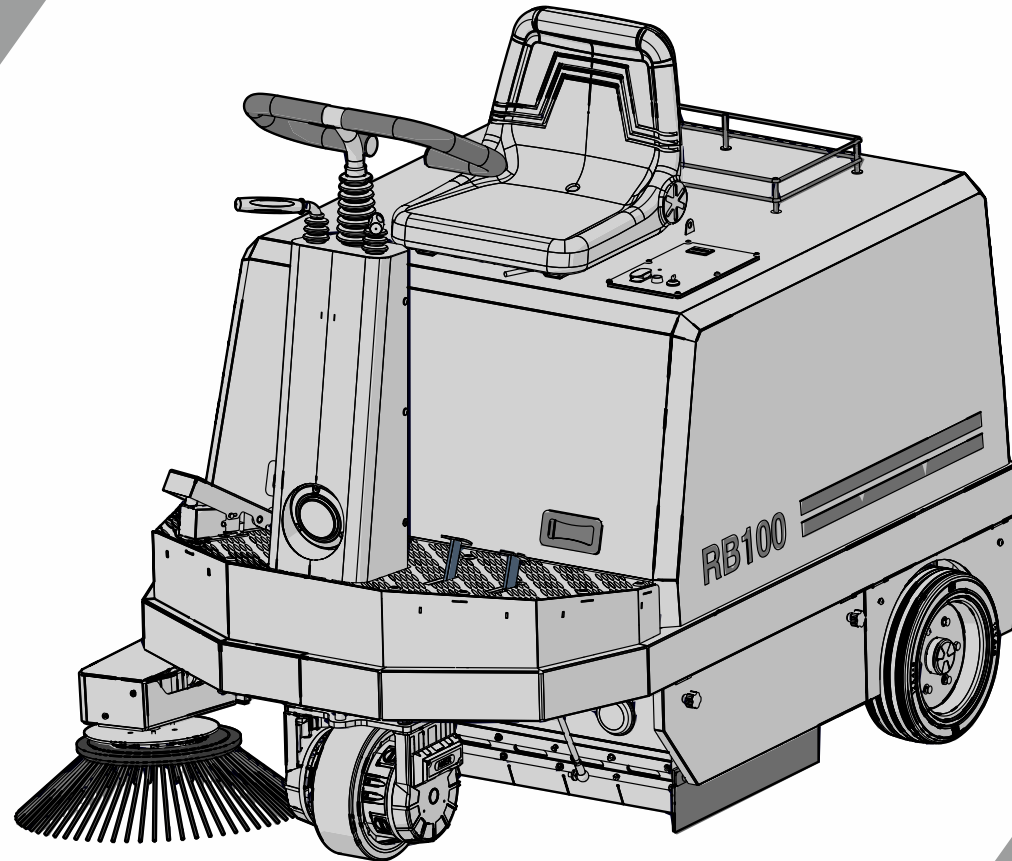
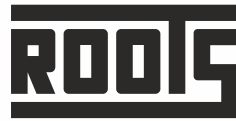

24V

Owner's Manual

Read this manual completely and understand the instructions before operating the machine.
"English Version"

TABLE OF CONTENTS



	Table Of Contents & Important Note	3
	Introduction	4
	Technical Specifications	5
	After Sales Support	7
	Safety Instructions	8
	Know Your Machine	12
	Controls	14
	Machine Operation	15
	Maintenance	19
	Troubleshooting	20
	Do & Don'ts	21
	Battery Instructions	22
	Operator Notes	26

IMPORTANT NOTE:

Roots Multiclean Ltd. (RMCL) is not liable for any legal claims that may arise as a direct or indirect result of the contents of this manual.

Roots Multiclean Ltd.
R.K.G. Industrial Estate, Ganapathy,
Coimbatore - 641 006, India.

MACHINE DATA

Please fill at the time of installation for future reference:

Model No. - _____

Serial No. - _____

Accessories - _____

Installation Date - _____

P/N: 557510008-00, Rev-F, 07/2018

Prepared by KM, NPM TD Dept.

INTRODUCTION



PREFACE

Dear Customer,

We are pleased with you having chosen the **RootsSweep RB 100** machine for your cleaning requirements. Backed by our industry expertise that spans across two decades, we assure you that the machine comes with ROOTS promise of quality, efficiency and performance.

We advise you to carefully read through the instructions prior to the operation of the machine. This manual contains detailed instructions for the proper operation of the machine, along with important information regarding its handling, care, maintenance and service needs.

We are sure that you will find the machine and its performance to your utmost satisfaction. Once again, we thank you for choosing us as a trusted partner for your cleaning requirements.

Usage, Handling & Modification

Use of the product beyond the specified scope of functioning is deemed improper and the manufacturer cannot be held liable for any damages which may arise due to this.

This machine may be used only by persons who are trained or are familiar with the machine and are aware of the possible hazards involved. The appropriate Accident Prevention Regulations as well as applicable general regulations pertaining to Safety and Health at the work place must be adhered to by the user.

Modifications made to machine without the manufacturer's consent will relieve the manufacturer of responsibility and any possible liability for consequential damage.

Notes on Warranty

Refer the Warranty manual supplied along with the machine.

Acceptance of the Machine

On arrival of the machine at the shipping address, please check for any damage that may have occurred as a result of transit. In the event of any such damage, the purchaser is bound by responsibility to send a claim letter to the concerned authorized dealer with a copy of the invoice. The letter should be sent within 24 hours of receipt of the machine.

NOTE:

ILLUSTRATIONS SHOWN IN THIS MANUAL ARE FOR REPRESENTATIVE PURPOSE ONLY. ACTUAL PRODUCT MAY VARY.

ROOTS reserves the right to change the product or contents of this manual without prior information.

For Engine, Battery, Motors, Blowers or other OEM components related information kindly refer to their manufacturers manual supplied along with the machine for instructions regarding usage, maintenance and service.



Prior to first operation, read the manual carefully and strictly comply with the instructions contained.

The Operator's Manual is an integral part of the machine and must not be misplaced.

TECHNICAL SPECIFICATION



ELECTRICAL SYSTEM

Total Power (input power)	-	1750 W
Drive Motor Power (output power)	-	800 W
Suction fan motor/sweeping (output power)	-	750 W
Battery Rating	-	6V/200Ah
Batteries	-	4 Nos.
Power Supply (DC)	-	24 V



HOPPER

Hopper Volume (Theoretical)	-	2 X 35 liters
-----------------------------	---	---------------

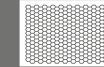

FILTER

Filter Area	-	3 m ²
No. of Filters	-	1

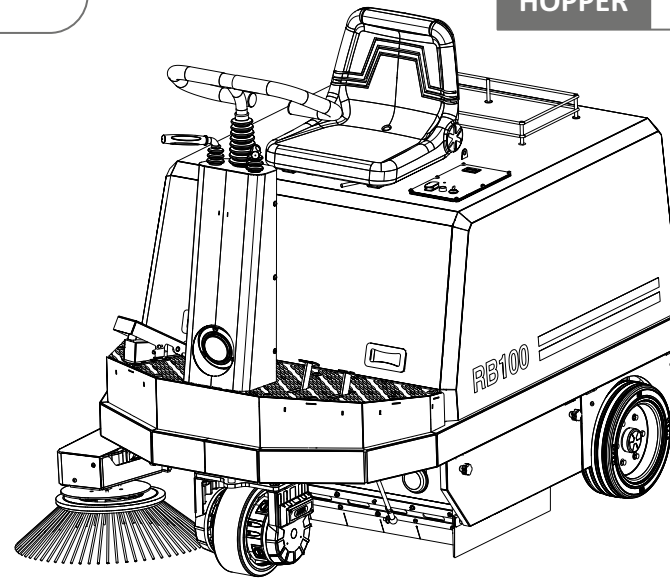

SWEEPING PERFORMANCE

With One Side Broom	-	1000 mm
Theoretical Area Coverage	-	6500 m ² /hr



WEIGHT

Dead Weight	-	460 kg
Admissible	-	
Total Weight	-	650 kg

TECHNICAL SPECIFICATION

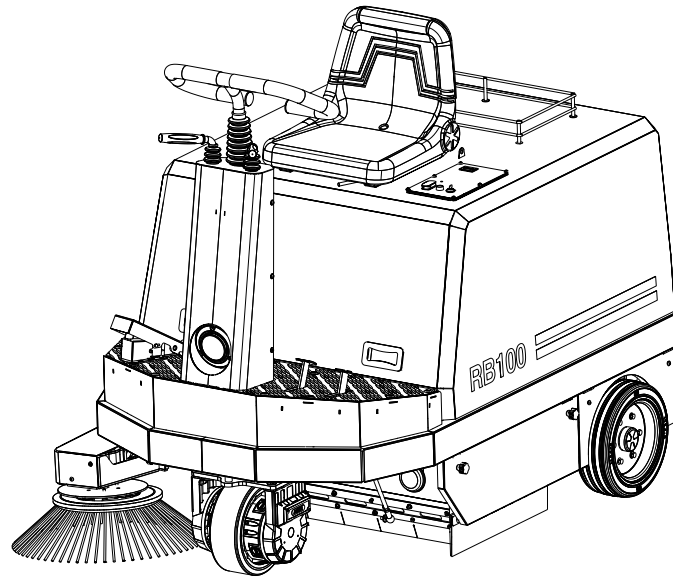

DRIVING PERFORMANCE

- Sweeping Speed up to - **6.5 km/hr**
- Forward Speed - **6.5 km/hr**
- Reverse Speed - **4 km/hr**
- Gradability, max. (for 1 min, max) - **12 %**



SIDE BROOM

- Diameter - **500 mm**
- Speed - **90 rpm**



CYLINDER BROOM

- Length - **750 mm**
- Diameter - **350 mm**
- Wearing Limit (diameter) - **295 mm**
- Speed - **480 rpm**
- Sweeping Track - **50 mm**
- Quantity of Bristle Row - **12 - V Shape**

DIMENSIONS:

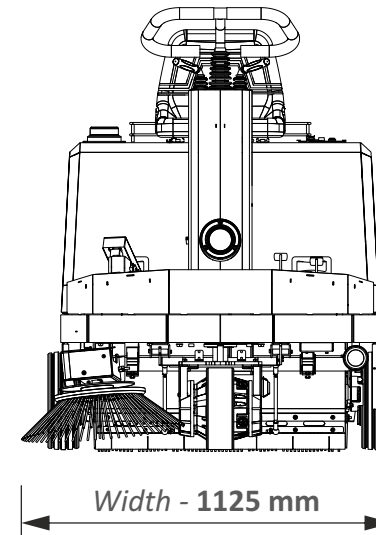
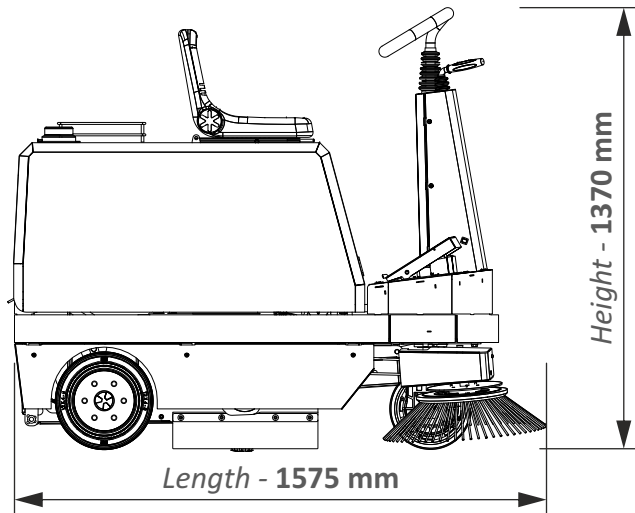

AFTER SALES SUPPORT



AMC

CUSTOMER SUPPORT SYSTEM (CSS)

RMCL has a dedicated CSS Team to ensure prompt after sales service support. One call solution for all your complaints/concerns. Register your complaint or concern through the below toll free number for hassle free support. The customer support executive registers your complaint/concern and will keep you updated on the progress.

Toll Free Number:

1800 41 99 77 9

Our timings (Monday to Saturday):

8:00 am to 7:00 pm

Customer Support System Process

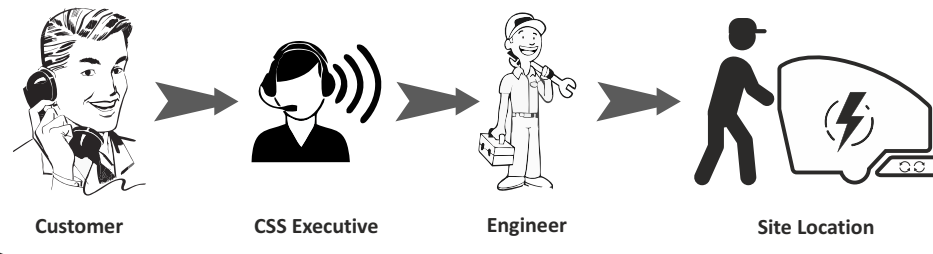

Our Address:

Roots Multiclean Ltd.

R.K.G. Industrial Estate, Ganapathy, Coimbatore - 641 006, India.

Phone: +91 (422) 4330 330, E-mail: rmclsales@rootsemail.com

Web: rootsmulticlean.in

Toll Free: **1800 41 99 77 9**

ANNUAL MAINTENANCE CONTRACT (AMC)

AMC or Annual Maintenance Contract is a professional and timely maintenance cover offered by RMCL to its customers. AMC takes care of scheduled and preventive maintenance services. Equipment under AMC qualifies for four scheduled visits and to a maximum of twelve unscheduled visits during the contract.

Advantages of AMC:

- Pan India network presence.**
- Maximum equipment uptime.**
- Focus on your business while we take care of your equipment.**
- Well trained engineers to take care of the equipment.**
- System driven scheduled periodic maintenance.**
- Genuine spare parts.**
- Toll free number assistance for breakdown.**

SAFETY INSTRUCTIONS

GENERAL SAFETY SYMBOLS



**Read
manual**

Prior to first operation, read the manual carefully and strictly comply with the instructions contained.



**Caution
(the machine)**

Important information on handling the machine in order to maintain operability.



**Ecological hazard
(the environment)**

Due to use of substances representing an inherent danger to health of environment.



**Safety Provisions
(persons & goods)**

Safety provisions in dangerous situation caused by misuse inaccurate adherence of instruction or prescribed work routine.



General Guidelines

- In addition to the information contained in this manual, generally applicable legal provisions for Safety and Prevention of accidents must be adhered to.
- Please go through the manual and the instructions contained herein carefully, even if you possess prior experience in operating similar ground cleaning equipment.
- Schedule some time for the careful and thorough perusal of the manual contents.
- The responsibility of all persons in the working area fall upon the operator of the machine.
- No persons, children included, should be allowed within the zone of danger.
- The warning and instruction plates attached to the machine carry important advice on safe operation of the machine.
- Lost or illegible stickers must be replaced at the earliest.
- Prior to operation of the machine, the operator must ensure that the machine and its working implements are in proper and safe operating condition.
- Machines with identified and known defects must not be used.
- It is important that operators and all persons likely to use the machine familiarize themselves with all accessories and controls, as well as their functions, before commencing operation.
- Adherence to the above general instructions will help avoid the operator from having to read the manual while operating the machine.

Safety during machine operation

- The machine is applicable for DRY sweeping only.
- Ground cleaning machines may be run by qualified personnel only.
- The machine may be used for cleaning such surfaces approved by the owner or this authorized representatives.
- The machine is only suitable for use on the types of surfaces specified in the owner's manual.
- Protect the machine from frost or extremely low temperatures.
- Never vacuum up explosive liquids, combustible/ explosive dusts as well as acids and solvents! This includes diesel, petrol, kerosene, paints, paint thinners, heating oil, etc which can generate explosive fumes on contact with the suction air. Acetone, undiluted acids and aggressive solvents must not vacuumed as it may cause damage to the machine components and brooms.
- Do not sweep/vacuum burning or glowing debris.
- Do not sweep/vacuum in wet, flooded and slushy areas.

SAFETY INSTRUCTIONS

- This machine must not be operated by persons (including children) with limited physical ability, sensoric /mental capabilities or lack of experience, unless such persons are supervised by the person in charge.
- Children should be prevented from playing with the machine.
- The operator must use the machine properly. The operator must consider the local conditions and must pay attention to third parties especially children when operating the machine.
- Never leave the machine unattended when the motor is running.
- The operator must leave the machine only after the motor has come to a complete standstill, parking brake applied and the key has been removed.
- Prior to starting work, the operator has to check the machine's safety devices are working properly.
- The operator must wear tight fitting clothes only. The operator should wear safety shoes only when operating or while carrying out maintenance work.
- Loose fitting clothes or shoes must not be worn by the operator or any maintenance personnel who are intended to work on/with the machine.
- Check the immediate surrounding prior to starting. Ensure sufficient visibility!
- The operator must always use safety gloves, safety helmet, shoes while operating/maintaining the machine.
- On inclined/tilted surfaces, the tilt angle and the driving direction should not exceed the values given in this manual.
- Do not place any tools or metallic objects on top the battery. Risk of short circuit and deflagration!
- Smoking or naked flames are strictly prohibited.
- Always allow the machine sufficient time to cool before carrying out any repair or maintenance work.
- Ensure that there is adequate ventilation for diverting the exhaust gases/dust when operating the machine in a closed area.
- Do not place hand or any object while the brooms are running.
- Suitable tools must be used for cleaning and maintenance work.
- Do not carry out any welding, drilling, sawing or grinding work on the frame sections. Damaged parts may only be changed at an authorized service center.
- It is not permitted to use aggressive and corrosive cleaning agents.
- Used batteries with the recycling symbol must not be disposed of in household waste.
- Maintenance work may be carried out by Roots/authorised dealer only.
- Always use appropriate tool and equipments while working on the machine.
- Disconnect the battery when working on electrical system.
- Battery may only be handled and changed by properly skilled maintenance personnel.
- Pay attention that the insulation of the charger cable is not damaged and cannot be damaged during the charging process.



- The cable must not chafe against anything. In the case of defective insulation, do not use the on-board charger.
- When charging the batteries, there must be sufficient ventilation in the charging area. Otherwise, there is a risk of explosion!
- Batteries must not be connected or disconnected when conducting electricity.
- Do not use harsh chemicals to clean the machine.



This machine is not suitable for evacuation of dusts, which are explosive or dangerous to health.

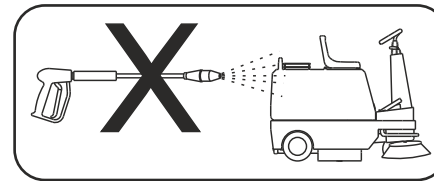

DO NOT CLEAN THE MACHINE BY MEANS OF VAPOUR JET OR HIGH PRESSURE CLEANING EQUIPMENT.

- Before operating the machine kindly use these safety devices:

- i) Shoes
- ii) Helmet
- iii) Gloves











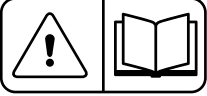

- Do not smoke near machine.
- Do not expose machine to naked flames or burning debris.

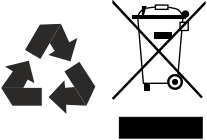
SAFETY INSTRUCTIONS

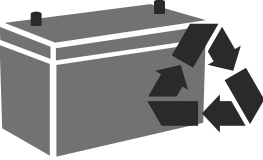
SYMBOLS & HAZARDS PICTORIAL DEFINITIONS

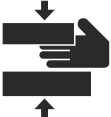

 <p>Read Manual</p>	 <p>Information</p>	 <p>General Warning</p>	 <p>Caution</p>	 <p>Toxic Hazard</p>
 <p>Recycle/Do Not Throw In Garbage</p>	 <p>Environmental Hazard</p>	 <p>Battery: Recycle</p>	 <p>No Fire/Matches</p>	 <p>No Smoking</p>
 <p>No Passengers</p>	 <p>Do Not Throw In Garbage</p>	 <p>Hand Crush Hazard</p>		

SAFETY INSTRUCTIONS



ENVIRONMENTAL RESPONSIBILITY



The packaging material can be recycled. Please do not place the packaging into the ordinary refuse for disposal, but arrange for the proper recycling.



Old machines contain materials that can be recycled. Please arrange for the proper recycling of old machines. Batteries and actuators contain substances that must not enter the environment. Please dispose of your old machines, batteries and actuators using appropriate collection systems.

KNOW YOUR MACHINE

Main Components of the Sweeper

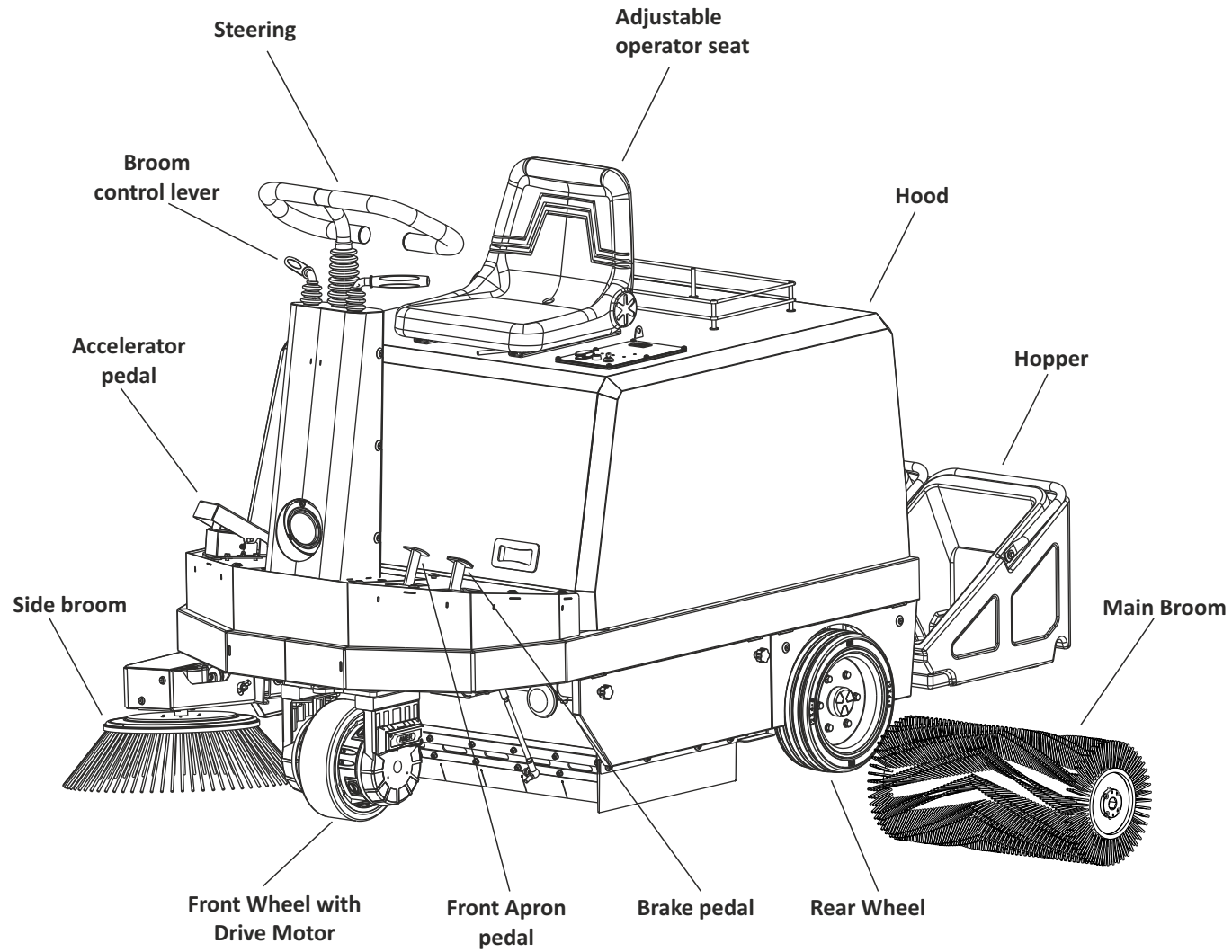

KNOW YOUR MACHINE



Identification of Main Parts

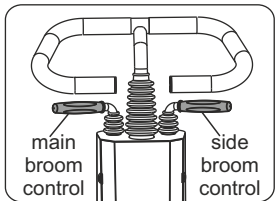

Control levers

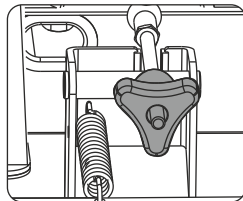

Main broom adjustment

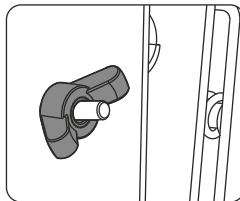

Side broom adjustment

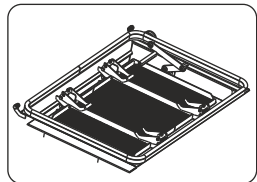

Filter

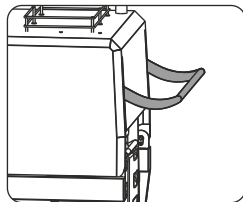

Hopper lock handle

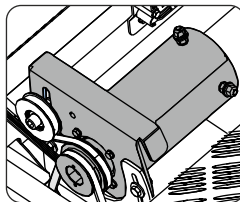

Main Motor

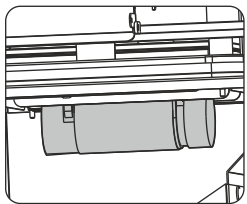

Vibrator motor

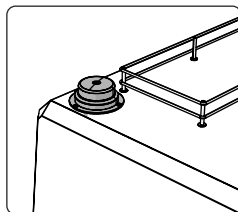

Beacon lamp



Control panel

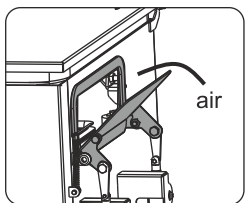

Bypass

Decals on the machine

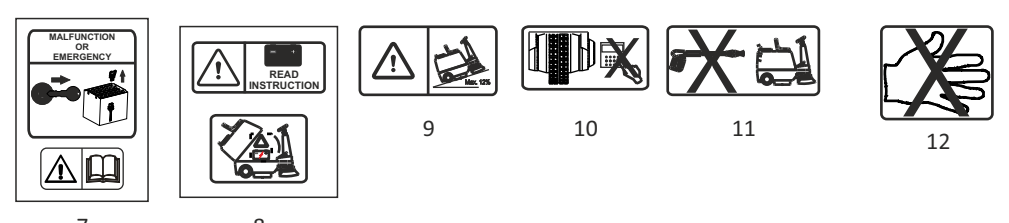
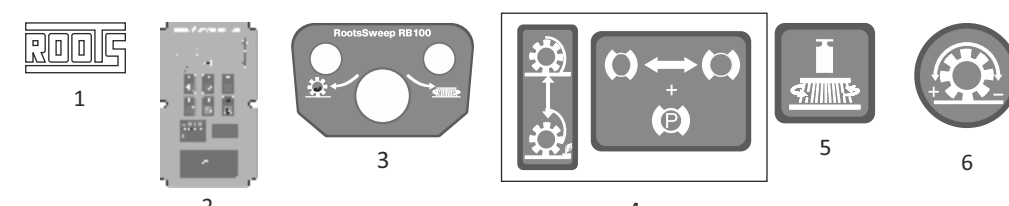
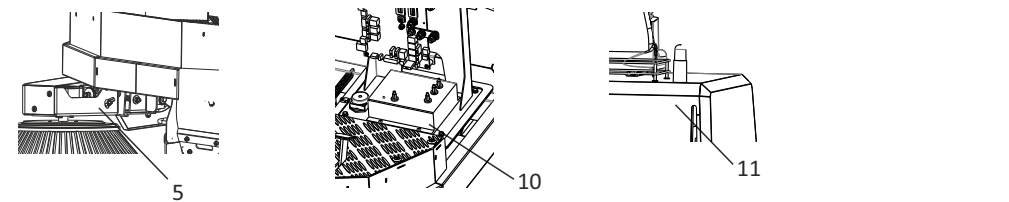
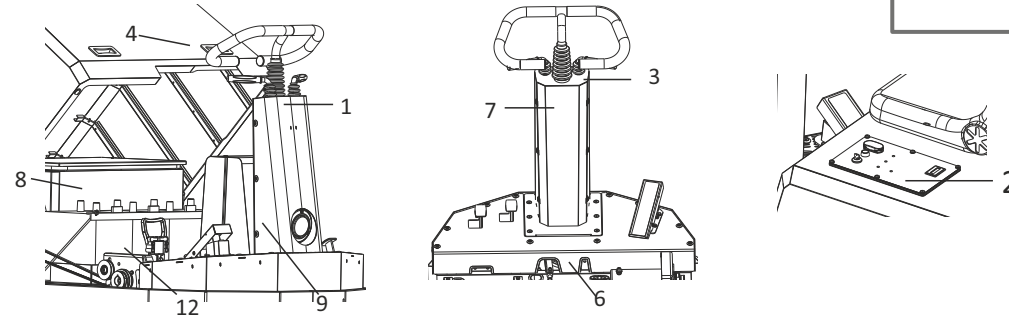

- 1. Roots - Silvergrey
- 2. Control Panel sticker
- 3. Broom controller lever sticker
- 4. Front apron & Brake
- 5. Side broom wear adjustment
- 6. Main broom wear adjustment

- 7. Remove key / Read Instruction
- 8. Battery Instruction / Open hood
- 9. Max gradability
- 10. Do not tamper
- 11. Do not wash with HPJC
- 12. Pinch warning

CONTROLS

Operating & Indicator Elements

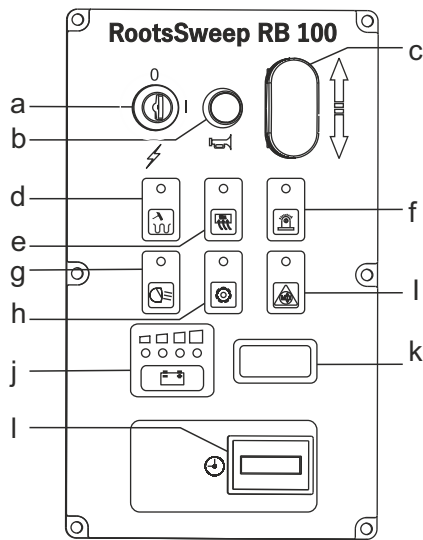

a) Key switch-
Turns the electrical system ON/OFF.



b) Horn button-
Actuates the electric horn.



c) Direction selector-
Selects the direction(Forward/Backward) of travel.

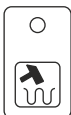

d) Filter shaker-
Used to activate the filter shaker.

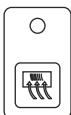

e) Wet bypass-
Suction by-pass switch to cut off suction to the dirt hopper and dust filter chambers.

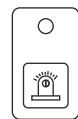

f) Beacon lamp (ON/OFF)-
Toggles the beacon lamp On or Off.

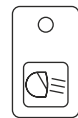

g) Working lamp (ON/OFF)-
Toggles the working lamp On or Off.

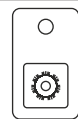

h) Main motor-
It glows when the brush motor is on.

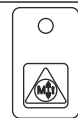

i) Drive motor error-
It glows when the problem occurs in drive motor.

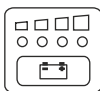

j) Battery charge status indicator lamp-
Shows the status of the battery.

k). Display layout of LCD

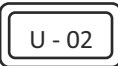

i) Shows the software version when the machine is switched On.



ii) Shows the battery type.
(LA, AGM, GL)

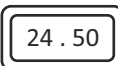

iii) Display the Battery voltage.



l) Hour meter display-
Displays the total hours of machine use.

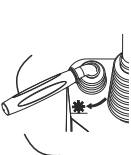

m) Main broom lever-
Push lever - Lower main broom as well as switch on main broom and side broom
Pull lever - Lift main broom as well as switch off main broom and side broom

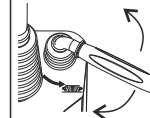

n) Side broom lever-
Push lever - Lower side broom
Pull lever - Lift side broom

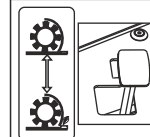

o) Front apron lift lever-
It is used to lift the front apron for leaf and light weight debris collection.

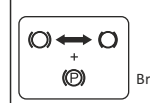

p) Brake with parking brake-
It is used to slow /stop the machine and engage /disengage the parking brake.



q) Main broom wear adjustment-
Used to adjust the main broom wear.



r) Side broom wear adjustment-
Used to adjust the side broom wear.



MACHINE OPERATION



Machine Operation:

It is the operator's responsibility to be knowledgeable of all potential operating hazards and to take every reasonable precaution to ensure safety of oneself, others, animals, and property.

This section of the Operator's Manual is designed to familiarize, instruct, and educate safe and proper machine use to the operator. The operator must be familiar with the machine operation and all associated safety practices before operating.

Proper operation of the machine, as detailed in this manual, will help ensure years of safe and satisfactory use of the machine. **READ, UNDERSTAND, and FOLLOW** the safety messages. Serious injury or death may occur unless care is taken to follow the warnings and instructions stated in the safety messages. Always use good common sense to avoid hazards.



WARNING

Do not operate a damaged or malfunctioning machine. Risk of equipment failure or cause of injury or death or damage to property.

Operator Requirements:

Only qualified people are allowed to operate the machine. A qualified operator has to read and understand the owner's manual and should comply with its procedures. If any part of the operation and safe use of this equipment is not completely understood, consult an authorized dealer for a complete explanation.

If the operator cannot read the manuals for himself or does not completely understand the operation of the equipment, it is the responsibility of the supervisor to read and explain the manuals, safety practices, and operating instructions to the operator.

Employer Responsibilities:

- Train the employee to operate the machine in a safe way.
- Permit only qualified personnel to operate and service the machine.
- Instruct all operators to maintain the shields and guards in its proper working condition at all times.
- Ensure that the operators use approved Personal Protective Equipment at all times or whenever required.
- Forbid the operators to carry additional people on the truck or the machine.
- Ensure that nobody including the operator modifies or alters the machine or any of its function, doing so may cause fatal injury or death or it may damage the machine itself.
- Ensure that the operator follows the state/country traffic rules at all times.
- Ensure that children do not operate the machine.

Before Starting The Machine:

Before operating the machine, ensure that the equipment is working properly and that you are prepared for vacuuming operations by checking the Pre-operative checklist and testing the machine operations.

MACHINE OPERATION



Principle of Operation

The machine operates on the overhead throw method.

- The rotating main broom sweeps the debris into the dirt hopper.
- The side broom sweeps the edges and corners and moves the debris to the path of the main broom.
- The fine dust from the swept debris is sucked by a internal vacuum system through a filter.

Useful Tips

- Never sweep long packing straps, ropes, threads, twines or wires as it could get entangled with the main and side broom and damage its mechanism.
- Make sure the area to be sweep is dry.
- Large debris which cannot be swept should be placed in the hopper manually.
- Remove the hopper in a non windy area to avoid dust from flying.
- For optimum cleaning results, match the driving speed with the area to be swept.
- Switch off suction fan if sweeping in a damp area as it may damage the filter.
- Clean the dust filter at regular intervals depending on the intensity of dust.
- Never wash the dust filter with water, use only compressed air.



Driving the machine

Connecting battery-

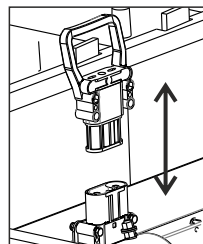
- Before starting up for the first time connect the male plug of battery to the female plug of the machine.
 - Before starting the machine, sit in operator seat and ensure if parking brake is engaged.
 - Do not adjust the seat while driving the machine.
- Do not drive the machine in flooded areas. Risk of damaging the drive motor.
- Because of skidding hazard drive at reduced speed on wet grounds and when turning.
 - Drive slowly on downhill, turning, wet grounds, ramps and on uneven surfaces.
- Never make sharp maneuvers while driving.
- Before leaving the machine make sure to remove the key.
- Not recommended to use the machine in tall hump.



- Before sweeping remove the bulky and oversized debris from aisles.
- Pick up loose wires, ropes, threads, etc. which could get entangled with the brooms and cause damage.
- Sweep in a long straight path as far as possible.
- Avoid bumping the machine into walls or posts, it may damage the machine.



- Maximum inclination of 12% (for 1 min. max) is only allowed.
- Do not park the machine on slopes or ramps.

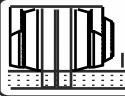

MAX 5.0 mm Water Level
Maximum water wading of **5.0 mm** is allowed.

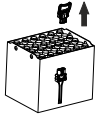

Do not tamper the drive motor controller. Risk of damaging the motor.

MALFUNCTION OR EMERGENCY   **In case of an emergency or malfunction - switch of key and disconnect battery plug.**

Starting-

- Sit in operator seat, disengage the parking brake and check if the direction selector is in neutral position.
- To start the machine turn the ignition key clock wise.
- Select the direction (Forward/Backward) of travel by direction selector & press the accelerator pedal.
- Move the machine to the area to be cleaned.
- Use head lamp for operating in low lit areas.

-  Do not use the machine for transporting goods or persons.
- Do not use the machine to pull/push other vehicles.
- Do not modify the machine.

Slowing-

- When the foot is taken off from the accelerator pedal the machine will slow down and will coast to a stop.
- To stop or slow the machine quickly, press the brake pedal downwards and release when stopped.

MACHINE OPERATION



Sweeping-

- Lower the main broom by push forward the main broom lever.
- When lower the main broom as well as the main broom & side broom are switched on.
- Lower the side broom by push forward the side broom lever.
- The side broom collects the debris away from corners and edges into path of the main broom.
- The main broom sweeps the debris from the floor and puts it into the dirt hopper.

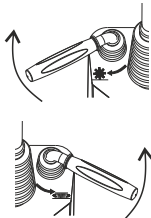

 Do not use the side broom when operating in dusty areas, chances of dust cloud is possible.

- The vacuum suction system pulls the dust into the hopper via filters.
- If sweeping has to be done in an damp area press the button to activate the suction bypass switch to cut off suction to the dirt hopper and dust filter chambers.

DANGER/CAUTION



- Do not sweep at a fast speed.
- Do not sweep hazardous debris.
- Do not modify the machine to transport people or goods.
- Do not drive fast when the hopper is full.
- Do not go on a steep downhill with a fully filled hopper.

 Failure to activate the suction bypass will result in filter damage.

 Ensure sufficient ventilation when sweeping indoors! It is forbidden to sweep up dust which represents a health hazard!

Stopping-

- Release the accelerator pedal.
- Lift up the main & side broom levers to stop the brush operation.
- Apply the parking brake.
- Turn the ignition key anti-clockwise to switch OFF the machine.

End of Sweeping-

- Operate the filter shaker.
- Empty the dirt hopper.
- Check the broom area for any residual waste and remove it if necessary.
- Clean the machine.

 Warning - do not clean electrical components with liquids! Risk of electric shock! It is not permitted to clean the machine with a pressure washer or steam cleaner.

Emptying the dirt hopper

Operating the shaking device:

Press the filter shaker button to clean dust from the panel air filter.



 Only operate the shaking device when the motor is switched OFF.

Lift the hopper link handle then remove the dirt hopper from the machine and empty it.

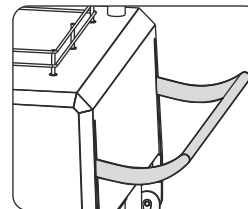

 Carry the dirt hopper by the handles.

 Observe the applicable laws and local regulations when disposing of waste.

Brooms

Main Broom Adjustment

- Open the hood.
- Turn the main broom control knob to adjust the wear of the main broom.
- Close the hood completely till it rests flat on the chassis.

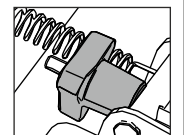

 Ensure the motor has stopped before opening the hood. Risk of injury through belt drive and rotating fan!

 With one turn of the knob, the track widens or broadens by approx. 10mm.

MACHINE OPERATION



Mounting & Dismounting of Main Broom

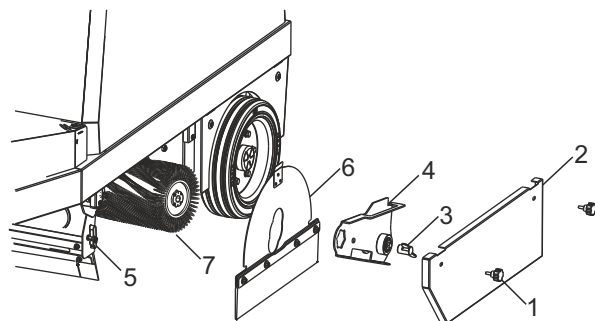

Dismounting

- Lower the main broom.
- Turn the ignition key anti-clockwise to switch off the machine.
- Unscrew the two knobs (1) and remove the side cover (2).
- Unscrew the knob (3) and remove the brush lock assy (4).
- Turn the lock knob(5) upwards and unlock.
- Pull the brush cover assy (6) downwards.
- Remove the main broom (7) by pulling it.

Mounting

- For mounting the main broom follow the reverse order of dismounting.

Side Broom adjustment

- Turn the side broom control knob to adjust the wear of the side broom.

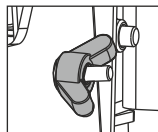

Mounting & Dismounting of Side Broom

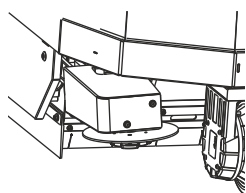

- Lift the side broom.
- Turn the ignition key anti-clockwise to switch off the machine.
- Rotate the broom clock wise or anti-clock wise with a sudden jerk to mount/dismount the broom.

Filter

Mounting & Dismounting of Filter

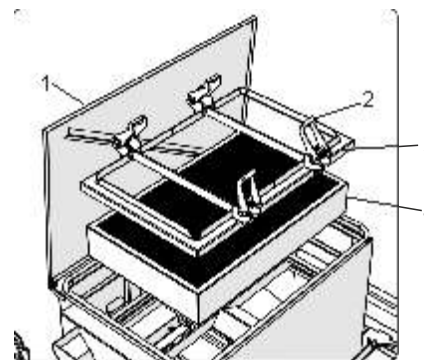

Dismounting

- Open the hood.
- Open the filter cover (1).
- Unlock lever toggles(2) to remove filter lock clamp assy(3)
- Then lift the filter (4).

Mounting

- For mounting the filter follow the reverse order of dismounting.

Filter cleaning

- Lift the filter from the hopper and clean them with compressed air (max. 1 bar).
- Drop the filter from 1 meter height onto a level, solid surface. Be careful not to damage the filter ribs!
- Ensure that the perforated sheet is facing top side.

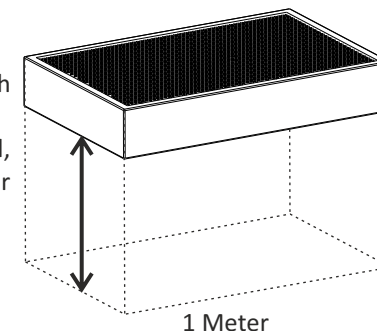

Do not inhale the dust. Health hazard! Wear an appropriate dust mask.



Do not contaminate the environment, use an appropriate cleaning chamber to dispose the dust.



Do not wash the filter with water or chemicals.

MAINTENANCE



WARNING

- *Maintenance and/or repair operations must be done by skilled and authorized personnel; all operations on the electrical and pneumatic devices are to be performed by specialized personnel only.*
- *Read this manual thoroughly before performing any repair or maintenance operations.*
- *For repair and/or maintenance of high reach areas of the machine, use a suitable work lift or working platforms.*
- *Use genuine Roots spare parts ONLY which are specifically designed for the machine.*
- *USE suitable PPE at all times when working or servicing the machine.*

IMPORTANT!

- **ENSURE THAT THE BATTERY CUT-OFF SWITCH IS IN OFF POSITION.**

Maintenance Schedule

Maintenance Schedule	Service			
	Daily	Weekly	Every 50 hours	Every 100 hours
Check cables for damages	✓			
Recharge batteries	✓			
Check battery acid level		✓		
Check battery for spill out		✓		
Check battery poles and apply petroleum jelly if required		✓		
Shake and clean the dirt hopper	✓			
Clean filter	✓			
Check seals for wear, damage and adjust		✓		
Check main broom for wear, damage and adjust		✓		
Check function of brake	✓			
Check belts for wear and required tension			✓	
Grease steering pinion				✓

TROUBLESHOOTING



Troubleshooting

Problem	Remedy
Machine fails to start	Check the Contractor coils fuse
	Check the battery voltage & wires
	Check the circuit fuse
	Check the key switch & wires.
Dust flying	Check the condition of main broom aprons
	Check the main broom pattern
	Check the hopper filter for any damage If filter clogged, clean the same
Low battery backup	Check whether front apron is in closed condition
	Check the function of battery charger & current consumption at battery cable during charging. Check the specific gravity of the electrolyte after charging.
	Check the battery voltage & electrolyte level
Main motor malfunction	Check the fuse
	Check the limit switch in main broom lever
	Check the carbon brush condition & motor wires
Drive motor malfunction	Check the fuse
	Check the fuse
Main broom not functioning	Check the belt tension
Side broom not functioning	Check the belt tension
Accelerator pedal not functioning	Check limit switch in accelerator
	Check the accelerator & wires to accelerator
Vibrator not functioning	Check the fuse
	Check voltage from the board
	Check the vibrator & Wires to vibartor

Problem	Remedy
Vacuum bypass actuator not functioning	Check the fuse
	Check voltage from the board
	Check the actuator & wires to actuator
Horn not functioning	Check the fuse
	Check voltage from the board
	Check the horn & wires to horn
Beacon not functioning	Check the fuse
	Check voltage from the board
	Check the beacon & wires to beacon
Working lamp not	Check the fuse
	Check voltage from the board
	Check the bulb & wires to working lamp
Reverse buzzer not functioning	Check the fuse
	Check the buzzer & wires to buzzer

DO'S & DON'TS



Do's

- ✓ Frequently check the belt condition & tension.
- ✓ Check the main broom & side broom for wear.
- ✓ Check the aprons for damage, if required replace.
- ✓ Check the tire condition for wear.
- ✓ Use the side broom only for cleaning corners & edges.
- ✓ During transport, brooms should be in lifted position.
- ✓ Drive slowly on inclines & slippery surfaces.
- ✓ Operate the filter shaker before emptying the hopper.
- ✓ Filter shaker to be used depending on the intensity of dust level.
- ✓ After machine use, clean the filter with compressed air.
- ✓ To collect light weight & small size of debris use the front apron lift lever.
- ✓ Empty the hopper once it is full.
- ✓ While using on wet floors, engage the wet bypass system.
- ✓ Motor carbon brush condition to be checked.
- ✓ Charge the batteries after it has been completely discharged (battery red LED blinks).
- ✓ Charge the batteries only in a well ventilated area.
- ✓ Check the battery electrolyte level and if required refill.
- ✓ Battery to be charged fully and to be used till the red LED blinks. This is for better battery life.

Don'ts

- × Do not charge the batteries between cleaning cycle.
- × Do not use the machine for transporting goods or persons.
- × Do not modify the machine.
- × Do not use the machine on water or liquids.
- × Do not park the machine on ramps or slopes.
- × Do not place any objects on the battery while charging.
- × Do not tamper with the electrical circuits.
- × Do not clean the machine with a high pressure cleaning system.
- × Do not collect ropes, wires & threads during sweeping.
- × Do not collect flammable liquids or hot materials.
- × Do not use the machine in tall humps & uneven surfaces.
- × Do not allow water to penetrate the panel board & batteries.
- × Do not drive fast when the hopper is full.

BATTERY INSTRUCTIONS

Before using the machine

Battery Plug Coding

All battery plugs at machines, batteries and battery charger units have to be coded with the colored coding pins according to the battery type and the charger unit plugs are/will be seteristic curve such that a modification of the curve (in relation to the battery type) requires changing of the plug coding nominal voltage.

Plug case of charger units:

Grey for fluid-filled batteries, Green for maintenance-free Gel batteries

Plug case of machine:

Yellow for both battery types

Socket case of battery: Grey for fluid-filled batteries :

Green for maintenance-free

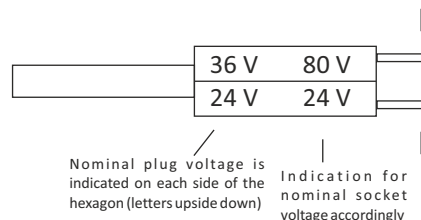

Replace the coding plugs by pressing the ends together with pliers.

Press together for removal

Insert coding plug such that the nominal voltage inscription is visible through the case window. Socket and plug only with the same nominal voltage.

The following three conditions have to be met:

- 1) Voltage coding must be the same for all sockets and plugs.
- 2) Coding pin color in the machine = yellow
- 3) Coding pin color in the charger unit = the same as for the battery plug according to battery type.



Open the seat console of the machine before performing charging operations.



Before first operation of the machine, fully charge the battery with an initial charging procedure and comply with the operating instructions of the charger as well as with those of the battery manufacturer. Roots cannot be held liable for damages resulting from the fact that the initial charging has not or insufficiently been done.

Coding system in the charger unit for fluid-filled batteries:

Example 24V Battery System

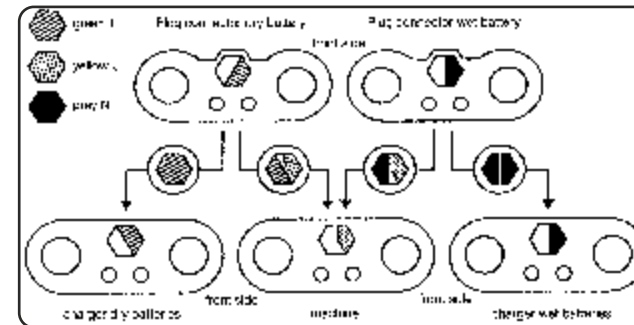

Battery charging procedure

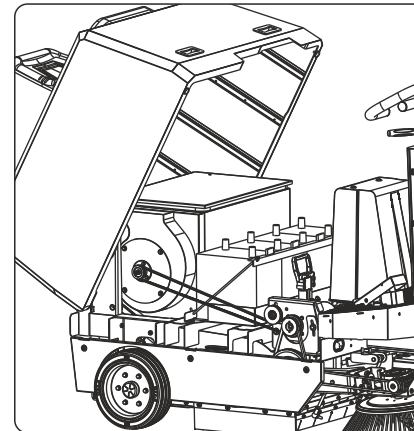

BATTERY INSTRUCTIONS



- Empty the hopper.
- Move machine near charger location.
- Switch Off Key.
- Remove key.
- Tilt hood backward completely.
- Disconnect the battery plugs and connect them to the charger supplied with the machine.

-  - Make sure to connect the charger to the specified voltage and frequency.
- Ensure that the hood is completely open.
- Do not place any objects on the battery.

-  Charge the batteries in a well ventilated area.
- Do not tamper with the charger settings.

SAFETY SYMBOLS FOR BATTERY SYSTEM



The above instructions have been established for your safety and have to be strictly observed.



-Observe the instruction which must be mounted clearly at the charging point!



-No Smoking!
-No naked lights, embers or sparks in the vicinity, risk of fire and explosion!



-Wear protective goggles and protective clothing when working on the batteries!



-Do not tilt the battery!
-Use only certified hoisting and transport equipment.



-Keep children away from batteries.



-Any splashes of acid in the eyes or on the skin must be rinsed thoroughly with plenty of clear pure water.
-Then consult a doctor immediately!



-Risk of fire explosion, avoid short circuits!
-**Caution!** Metal components in the battery cells are always under voltage, never place any foreign items or tools on the battery!



Electrolyte is highly corrosive!



-Charge in a well-ventilated area



-Do not throw in garbage!

BATTERY INSTRUCTIONS



Traction Batteries (LA)

1. Initial Checking-

Check the battery to ensure that it is in perfect mechanical condition. All screwed unions within the circuit must be tightened to ensure reliable contacts. Machine cables and charging cable are to be connected to the correct poles of the battery otherwise battery and charger can be damaged.

2. Discharging-

Ventilation openings may not be covered or closed. Electric connections (e.g-plugs) may be connected or disconnected only when the machine is in off condition. Discharge batteries must be recharged immediately and may not remain in discharged condition. This also applies to only partially discharged batteries.

The battery may only be connected up to the allocated battery charger certified for the particular battery size, to avoid overload on the electric current Maintenance Free Batteries have low gassing properties but are not completely free of gassing. The battery is to be connected with the correct poles (plus to plus and minus to minus) to the disconnected battery charger. The battery charger should then be switched on.

During the recharging procedure, the temperature in the battery increases by approx. 10 °C. For this reason, the recharging procedure may not be started unless the temperature is below 35 °C.

Before recharging the battery, the temperature should be at least 15 °C, otherwise the battery will not be correctly.

If the temperatures are constantly greater than 40 °C or lower than 15 °C, temperature-dependent constant voltage regulation of the battery charger will be necessary.

3. Temperature-

The battery temperature of 30 °C is rated temperature. Higher temperatures shorten the service life and lower temperatures reduce available capacity. 45 °C (51 °C for AGM) is the limit temperature and is not tolerable as operating temperature.

4. Electrolyte-

The electrolyte is sulphuric acid. The density of the electrolyte cannot be measured. Use the recommended electrolyte to top up.

5. Maintenance-

Daily maintenance- Recharge the battery every time it has been discharged.

Weekly maintenance- Visual inspection after recharging for signs of dirt and mechanical damage. Maintenance to be carried out every three months After

fully recharging and following a standing period of at least 5 hours, the following must be measured and Recorded: – total voltage / – individual voltage.

If noticeable changes are detected compared to previous measurements, or differences between the cells or block batteries, the customer service should be called for testing or repair.

6. Care-

The battery must be kept clean and dry to prevent creeping current. Any liquid in the battery container must be extracted and disposed of according to regulations.

7. Storage-

If batteries are out of operation for longer periods, they should be stored in fully charged state in a dry, frost free room.

In order to ensure that the battery is ready for operation at any time, it can be recharged according to one of the following methods:

1. Full recharge every three months. When a consumer is connected up (e.g. measuring or controlling devices), it may be necessary to recharge the battery every two weeks.
2. Maintenance recharging at a recharging voltage of 2.25 V x number of cells. The storage period is to be taken into account for the service life.

8. Faults-

The customer service should be called immediately when any faults are discovered in battery or battery charger.

Lead Acid (LA) Battery Instructions

- Kindly ensure that the Warranty certificate of the battery is available at your end.
- Kindly read the Do's & Don't's of the battery, understand and follow.
- Check the electrolyte level before charging and top it up with battery grade distilled water if required.
- Match the battery to the correct charger.
- Keep the battery well ventilated while charging.
- Charge the battery immediately after it is discharged completely.
- Keep all inter cell connections and bolted terminals tight and covered with petroleum jelly.

BATTERY INSTRUCTIONS



Battery connection diagram

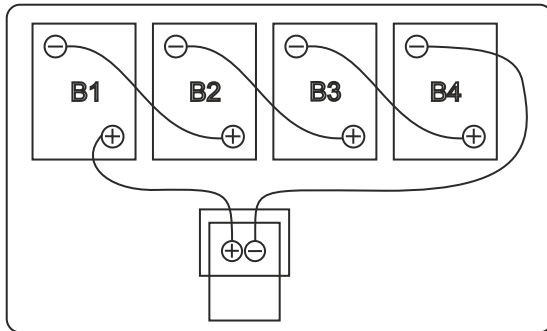

Battery & Charger specification

Battery specification

Type - LA
Rating - 6V/200Ah

Charger specification

Type - External charger
Rating - 30 Amps

Disposal of Batteries



Old batteries with this sign are recyclable economic goods and should be brought back into the recycling process. Old batteries which are not brought back into the recycling process, have to be dealt with as dangerous materials under the observance of all regulations.

OPERATOR NOTES



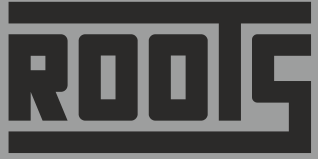

Roots Multiclean Ltd.

R.K.G. Industrial Estate, Ganapathy, Coimbatore - 641 006, India.

Phone: +91 (422) 4330 330, *E-mail:* rmclsales@rootsemail.com

Web: rootsmulticlean.in,

Toll Free: **1800 41 99 77 9**